

Installation Guide For:

IRON RAILING



Call 1-800-335-5909 for Installation Support

**This Packet MUST Accompany
Materials To Job Site**

Extra Screws Included



TABLE OF CONTENTS

POSTS	1
CAP RAIL CLIP.....	6
PANELS & BRACKETS.....	7
UNIVERSAL BRACKETS.....	8
GATES	17
ACCENT TOP RAIL	19
SECONDARY HANDRAIL	21

Fe²⁶

IRON RAILING SIMPLIFIED

POSTS



It is the responsibility of the installer to meet all code and safety requirements, and to obtain all required building permits. The deck and railing installer should determine and implement appropriate installation techniques for each installation situation. The Fortress Company or its distributors shall not be held liable for improper or unsafe installations.

Fortress Fe²⁶ Posts must always be secured to the deck framing. Fortress Fe²⁶ Posts should never be attached to only the deck boards.

Note

When cutting Fortress railing, it is very important to complete the following at cut points. Not following the below steps will result in rust at the cut areas:

- Remove all metal shavings from the cut area
- File any sharp edges left by cutting. Thoroughly wipe and remove any filings, grime or dirt from the railing.
- Apply two coats of Fortress zinc based touch-up paint to the cut area. Allow paint to dry.
- Be sure to remove any metal shavings from the surface of deck, patio or balcony to prevent rust on the surface.

Fe²⁶ 2" (51mm) Post Top Mount To Southern Yellow Pine or Douglas Fir Floor Joist Mounted Parallel

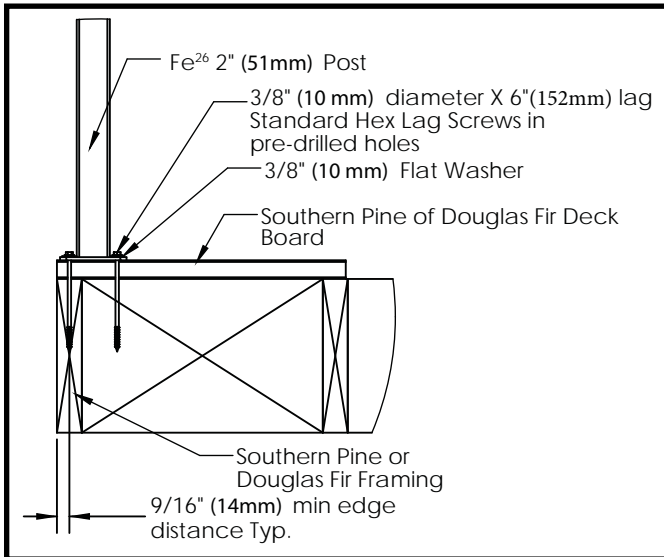

Fe²⁶ 2" (51mm) Post with through bolt & washers on bottom

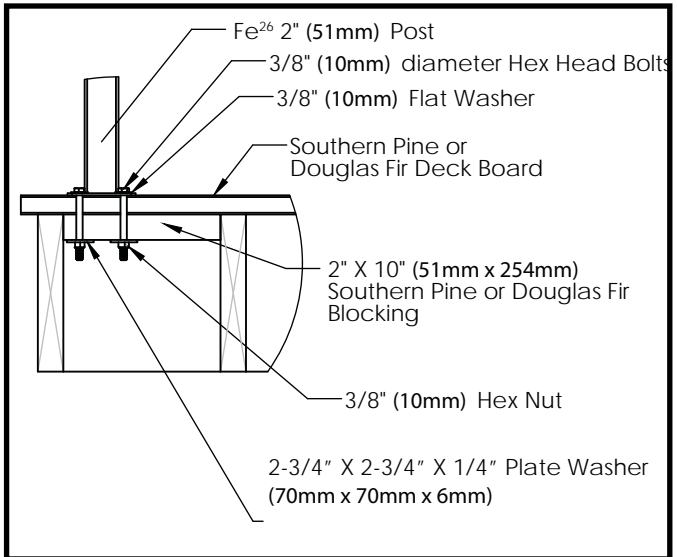

Fe²⁶ 2" (51mm) Post Top Mount To Concrete

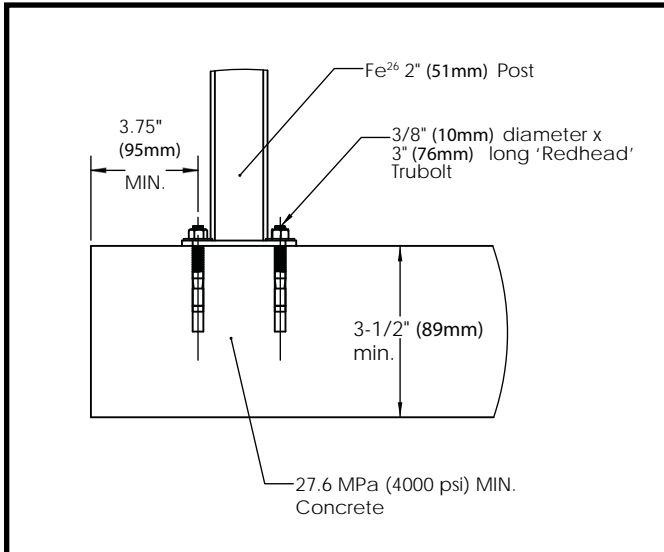

Fe²⁶ 2" (51mm) Post Top Mount To Southern Pine or Douglas Fir Floor Joist Mounted Perpendicular

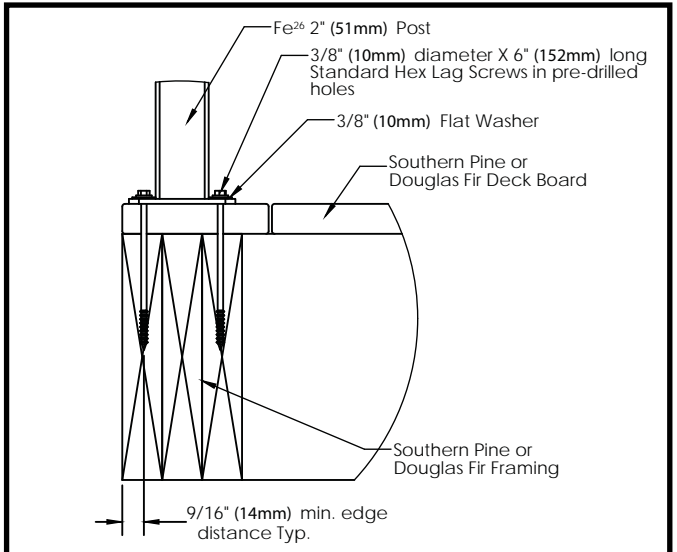

It is the responsibility of the installer to meet all code and safety requirements, and to obtain all required building permits. The deck and railing installer should determine and implement appropriate installation techniques for each installation situation. The Fortress Company or its distributors shall not be held liable for improper or unsafe installations.

Fortress Fe²⁶ Posts must always be secured to the deck framing. Fortress Fe²⁶ Posts should never be attached to only the deck boards.

Note

When cutting Fortress railing, it is very important to complete the following at cut points. Not following the below steps will result in rust at the cut areas:

- Remove all metal shavings from the cut area
- File any sharp edges left by cutting. Thoroughly wipe and remove any filings, grime or dirt from the railing.
- Apply two coats of Fortress zinc based touch-up paint to the cut area. Allow paint to dry.
- Be sure to remove any metal shavings from the surface of deck, patio or balcony to prevent rust on the surface.

Fe²⁶ 3" (76mm) Inch Post Top Mount to Southern Yellow Pine or Douglas Fir Floor Joist Mounted Parallel

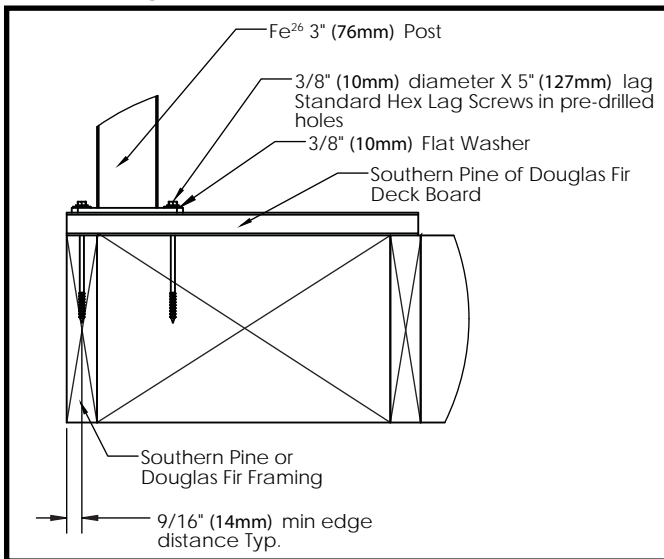

Fe²⁶ 3" (76mm) Inch Post with through bolt & base plate on bottom

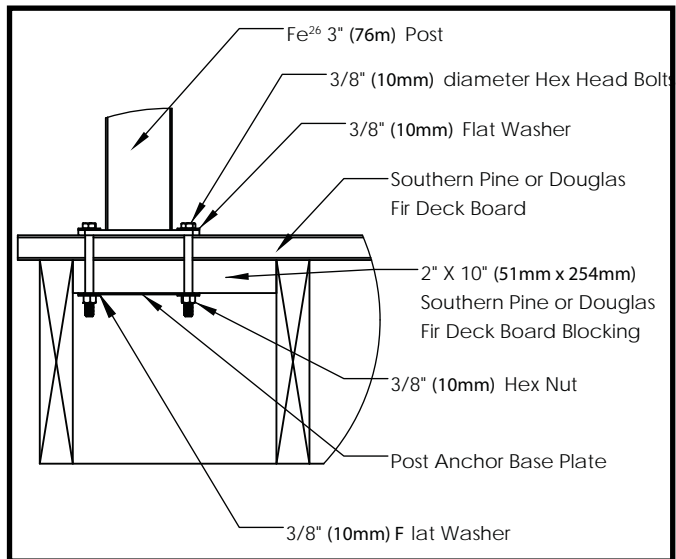

Fe²⁶ 3" (76mm) Post Top Mount To Concrete

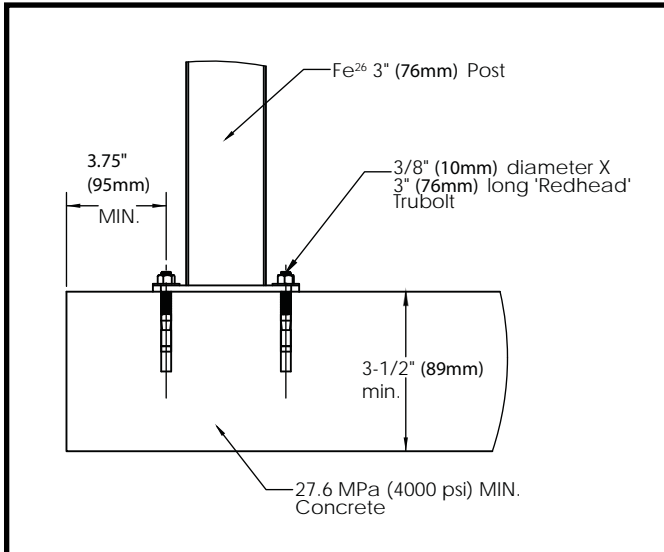

Fe²⁶ 3" (76mm) Post Top Mount To Southern Pine or Douglas Fir Floor Joist Mounted Perpendicular

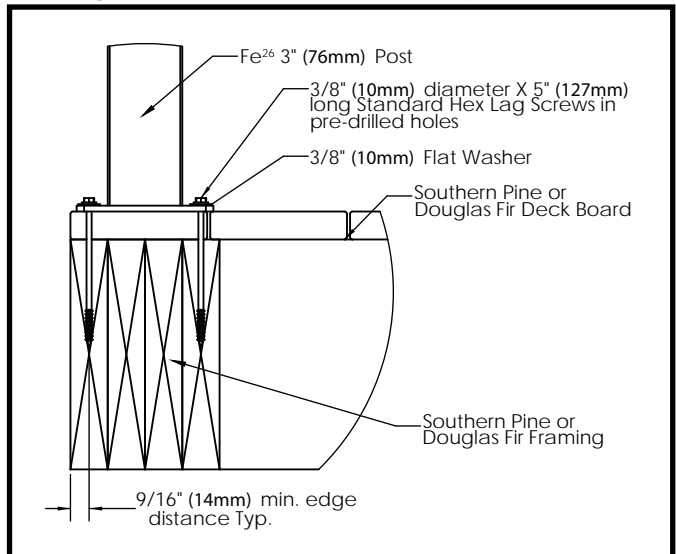

It is the responsibility of the installer to meet all code and safety requirements, and to obtain all required building permits. The deck and railing installer should determine and implement appropriate installation techniques for each installation situation. The Fortress Company or its distributors shall not be held liable for improper or unsafe installations.

Fortress Iron Posts must always be secured to the deck framing. Fortress Iron Posts should never be attached to only the deck boards.

Required Materials: Wood Blocking, 3/8" X 3-1/2" (10mm x 89mm) Hex Head Galvanized Bolts (4 for each post), 3/8" (10mm) Galvanized Washers (4 for each post), 3/8" (10mm) Fender Washers (4 for each post), 3/8" (10mm) Split Lock Washers (4 for each post), and 3/8" (10mm) Hex Nuts (4 for each post).

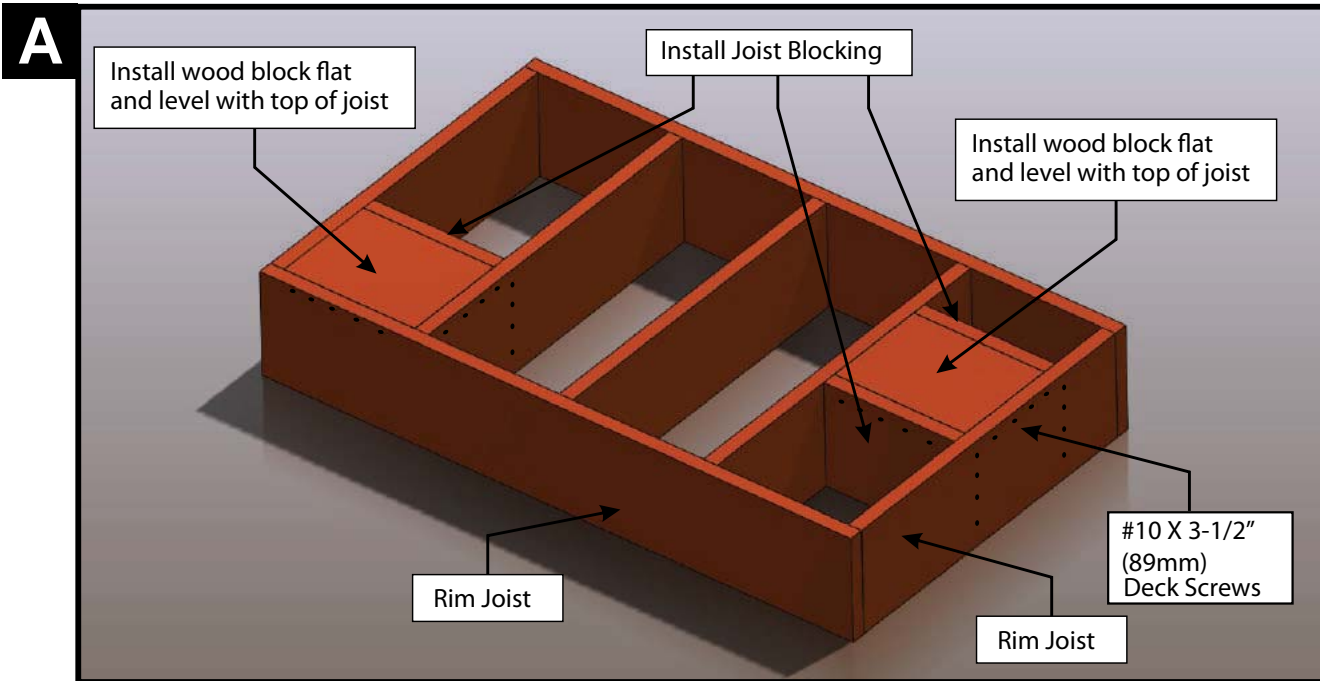

- Blocking must be constructed with treated dimensional lumber.
- Attach all blocking with #10 X 3-1/2" (89mm) deck screws.
- Wood Block must be constructed with treated dimensional lumber with a minimum thickness of 1 1/2" (38mm).
- Secure Wood Block to blocking on all four sides with #10 X 3-1/2" (89mm) deck screws.



Surface Mounting Fortress Iron Posts Installed on a Wood Deck

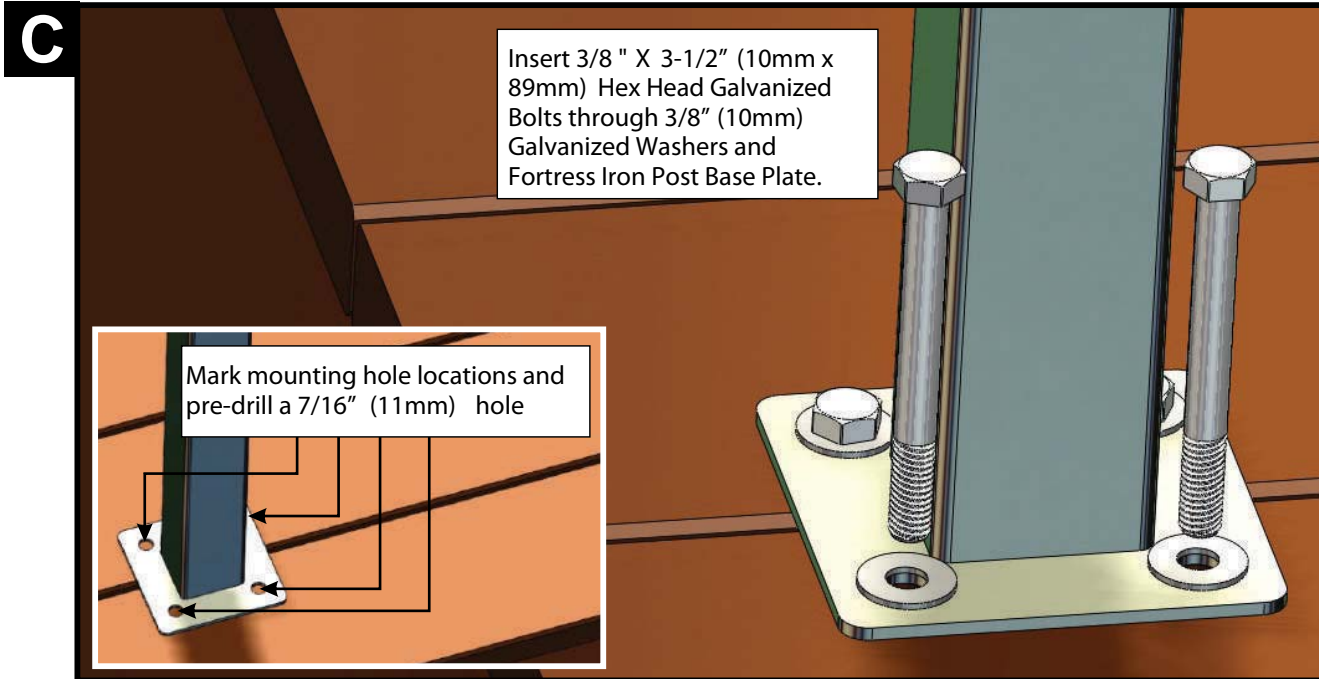

- Iron Post Base Plate holes **MUST** be positioned a minimum 1/2" (13mm) from edge of deck board.
- Use only 3/8" (10mm) Hex Head Galvanized Bolts. **Lag Screws should NOT be used.**
- Secure each post with four bolts.

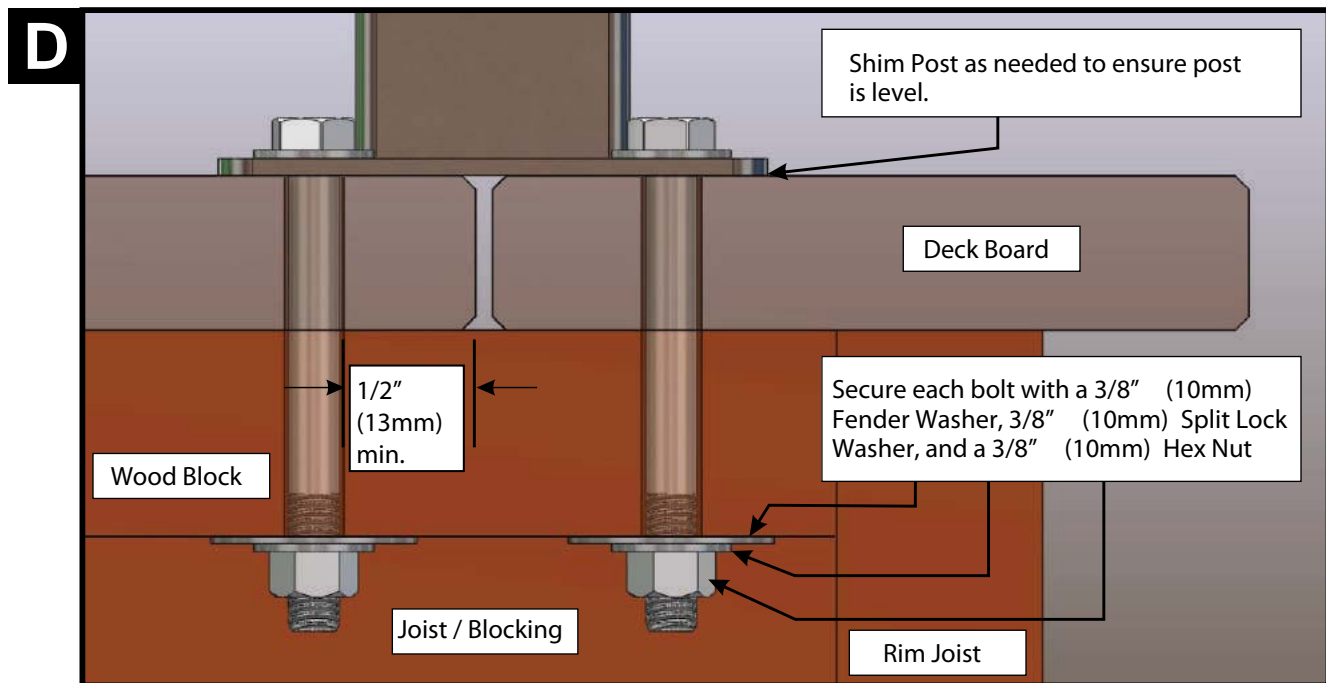

Installation Instructions for Fortres Fe26 Cap Rail Clip

It is the responsibility of the installer to meet all code and safety requirements, and to obtain all required building permits. The deck and railing installer should determine and implement appropriate installation techniques for each installation situation. The Fortress Company nor its distributors shall not be held liable for improper or unsafe installations.

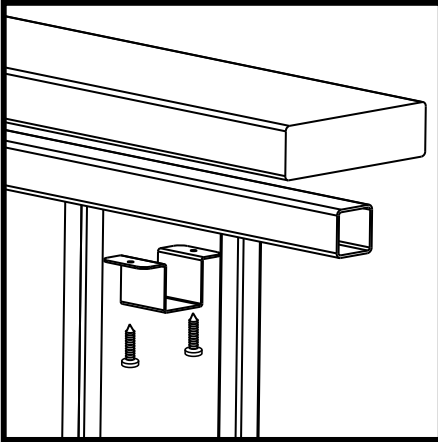

- **The Cap Rail Clip is not intended for structural use**
 - **Not designed for use with Fortress Fe²⁶ Ring Top Accent Top Panel**
 - **Minimum thickness of wood top rail is 3/4" (19mm)**
 - **Maximum recommended wood top rail width is 5-1/2" (140mm)**
 - **If the wood top rail is to be stained, complete staining before installation**
1. Cut the wood top rail to the required length.
 2. Center wood top rail on Fe²⁶ Traditional Railing Traditional Panel and clamp.
 3. Position a Cap Rail Clip a maximum of 6" (152mm) from the post at each end of wood top rail and mark the screw hole locations on the wood top rail.
 4. Space remaining Cap Rail Clips a maximum of 28" (711mm) on center along the wood top rail and mark the screw hole locations on the wood top rail.
 5. Remove the wood top rail and pre-drill at marked screw locations with a 1/16" (2mm) drill bit.
 6. Reposition wood top rail and secure Cap Rail Clip with supplied screws using a T-20 bit.

Fe²⁶

IRON RAILING SIMPLIFIED

PANELS AND BRACKETS



Installation Instructions for Fe²⁶ Traditional Railing Panels with Universal (UB) Brackets and Fe²⁶ Posts

It is the responsibility of the installer to meet all code and safety requirements, and to obtain all required building permits. The deck and railing installer should determine and implement appropriate installation techniques for each installation situation. The Fortress Company or its distributors shall not be held liable for improper or unsafe installations.

Fortress Fe²⁶ Posts must always be secured to the deck framing. Fortress Fe²⁶ Posts should never be attached to only the deck boards.

Note

When cutting Fortress railing, it is very important to complete the following at cut points. Not following the below steps will result in rust at the cut areas:

- Remove all metal shavings from the cut area
- File any sharp edges left by cutting. Thoroughly wipe and remove any filings, grime or dirt from the railing.
- Apply two coats of Fortress zinc based touch-up paint to the cut area. If touch up is at rail ends, allow paint to dry before connecting bracket to post.
- Be sure to remove any metal shavings from the surface of deck, patio or balcony to prevent rust on the surface.

Required Materials

Drill, 3/16" (5mm) Drill Bits, T-25 Driver Bit, Drill Bit Extender, Tape Measure, Wrenches, Speed Square, Center Punch, and Hammer.

Mount Fe²⁶ Posts*

- Wood Blocking tied to deck frame must be installed and constructed with treated dimensional lumber with a minimum thickness of 1-1/2" (38mm).
- Position the edge of Fe²⁶ Post base plate a minimum of 1/2" (13mm) from the inside edge of rim joist.
- Mount Fe²⁶ Posts at appropriate points based on panel length.
- Attach Fe²⁶ Posts with 3/8" X 3-1/2" (10mm x 89mm) Hex Head Galvanized Bolts.

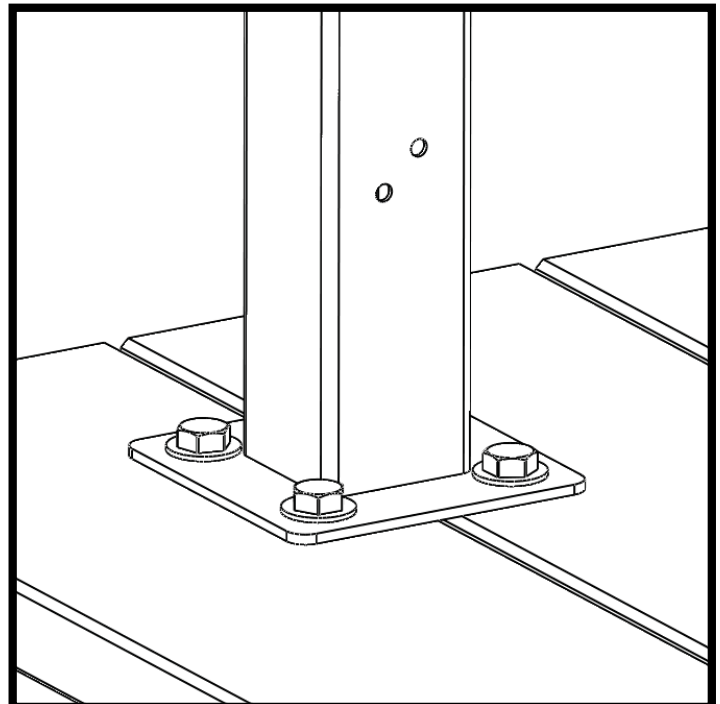
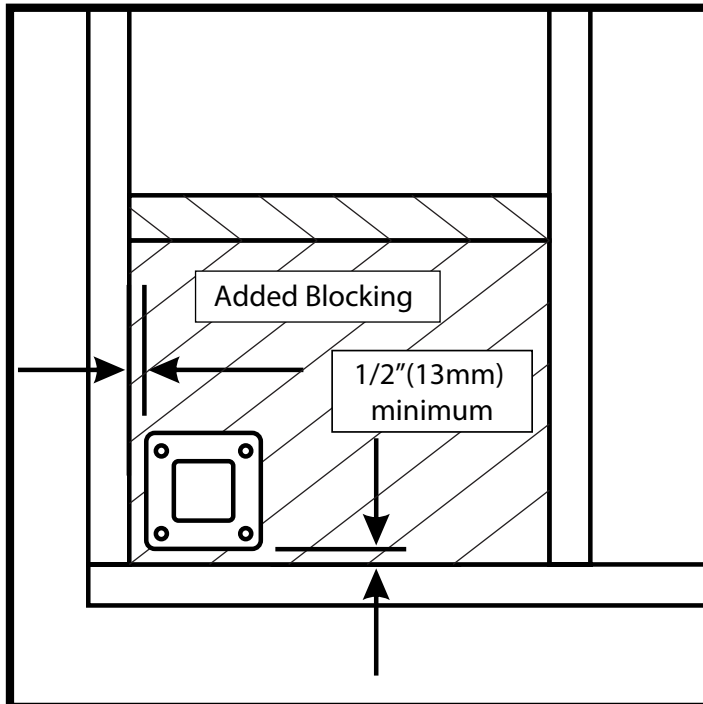

*Reference Fortress Fe²⁶ Post mounting instructions

Fe²⁶ Traditional Panel Installation Options

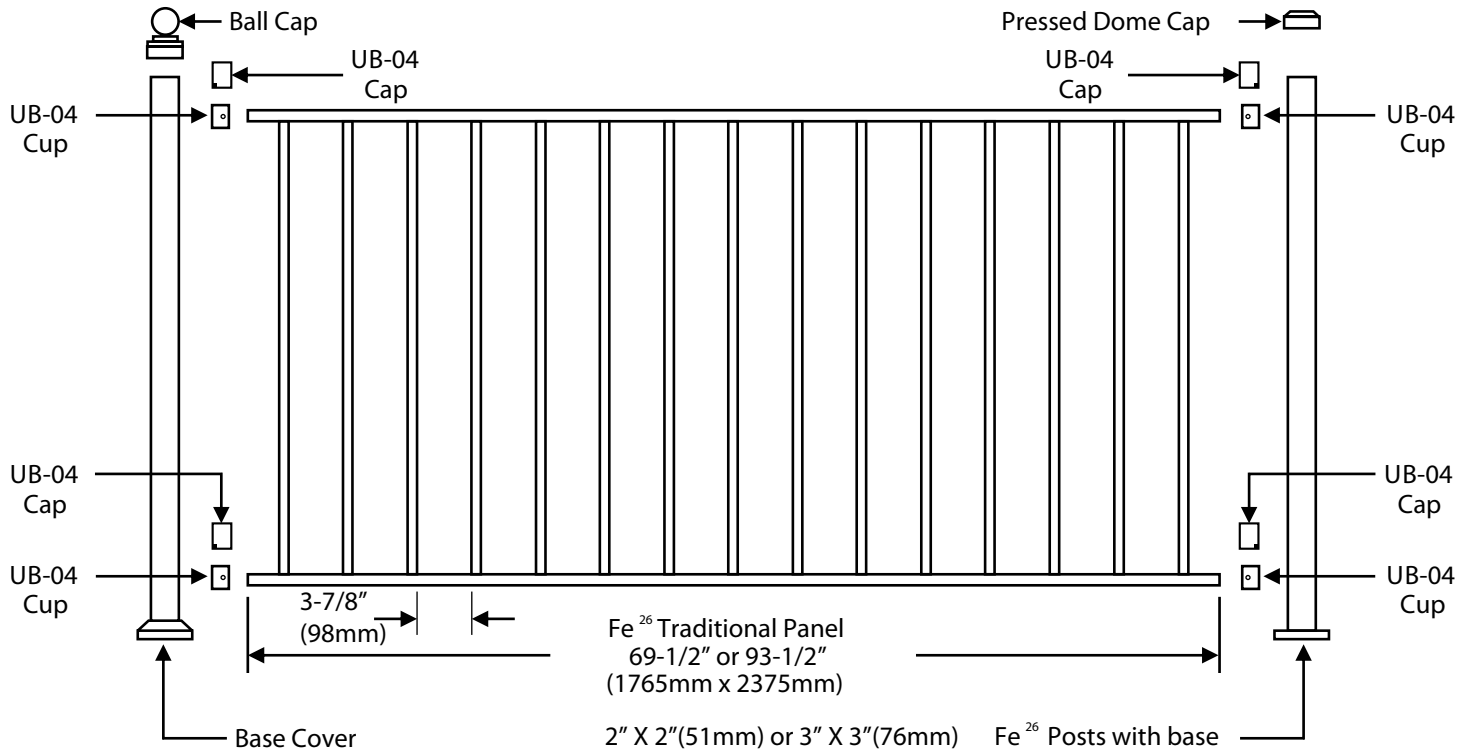

Fe²⁶ Traditional Panel with Accent Top Panel Installation Options

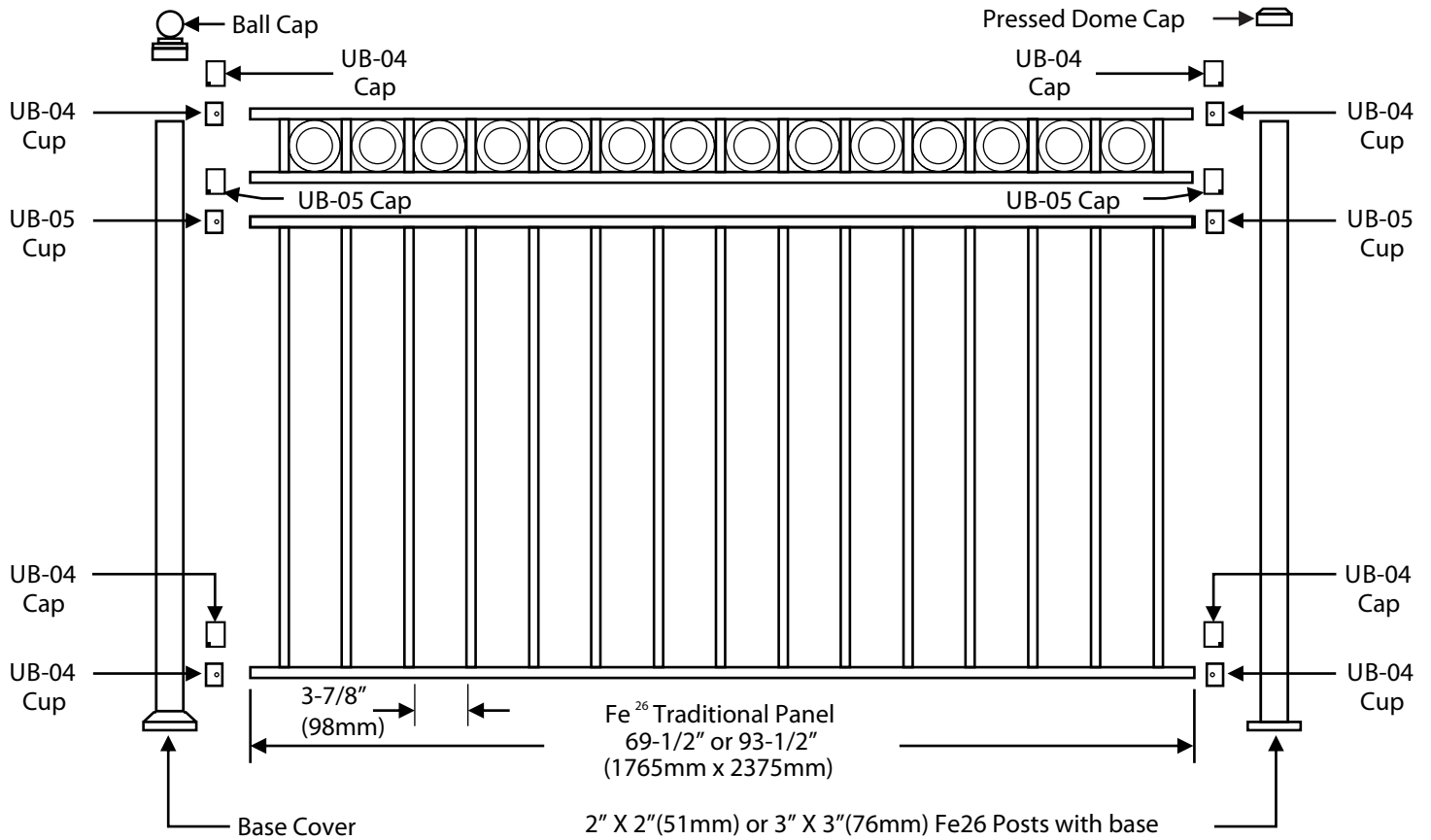

Fe²⁶ Traditional Panel and Fe²⁶ Post Configurations

Railing Panel Height	Railing Panel Only		Railing Panel with Accent Top Panel	
	Installed Panel Height*	Required Post	Installed Panel Height with ATP*	Required Post
28" (711mm)	X	X	36-1/2" (927mm)	39-1/2" (1003mm)
34" (864mm)	37-3/4" (959mm)	39-1/2" (1003mm)	42-1/2" (1080mm)	45-1/2" (1156mm)
40" (1016mm)	43-3/4" (1111mm)	45-1/2" (1156mm)	X	X

*Heights includes a 3-3/4" (95mm) space between deck surface and bottom edge of bottom rail.

UB-04 Bracket Hole Locations for Fe²⁶ Traditional Panel Installations

Pre-Drilling with a 3/16" (5mm) drill bit is required.

Rail Panel Height	Pre-Drill Dimensions			
	A*	B	C	D
28" (711mm)	X	X	X	X
34" (864mm)	4" (102mm)	1/2" (13mm)	37" (940mm)	1/2" (13mm)
40" (1016mm)	4" (102mm)	1/2" (13mm)	43" (1092mm)	1/2" (13mm)

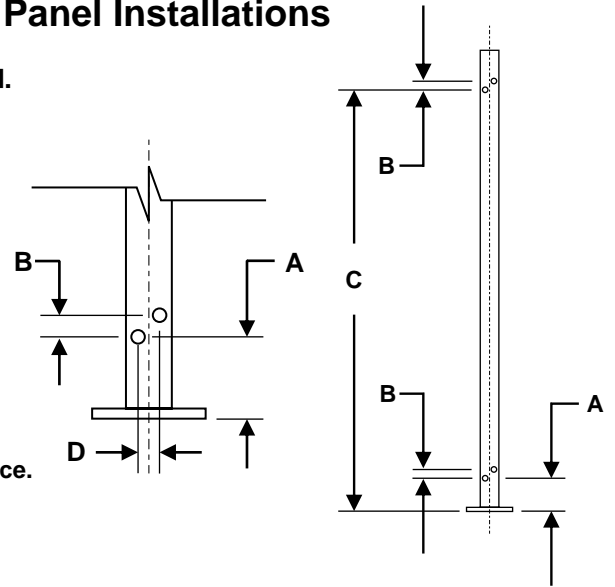

*Dimension A positions bottom edge of rail 3-3/4" (95mm) above deck surface.
*Dimension A is measured from the bottom surface of post base.

Remove all metal shavings from deck, post base cover, post, and panel before bracket is screwed to post to prevent rust stains.

Fe²⁶ Traditional Panel Installation with UB-04

When using UB-04 brackets rails **MUST** be cut 1/2" (13mm) shorter than the distance between posts. 1/4" (6mm) should be cut from the end of each rail to keep rail panel centered between posts.

- If rails were cut to length, file cut edges and coat with 2 coats of Fortress zinc based touch-up paint.
- Check fit of rail between installed Fe²⁶ Posts.
- If using a Base Cover install it now by sliding over the top of Fe²⁶ Post.
- Secure UB-04 brackets to Fe²⁶ Posts with provided T-25 Drive Thread Cutting Screws. Use two screws per bracket. Use low speed on drill.
- Drop Fe²⁶ Panel into installed UB-04 brackets.
- Secure rails with provided set screws at each UB-04 bracket.
- Install UB-04 Caps by sliding the cap over the UB-04 Cup. Cap will snap into place.

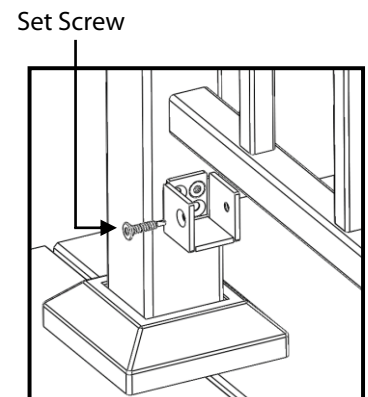
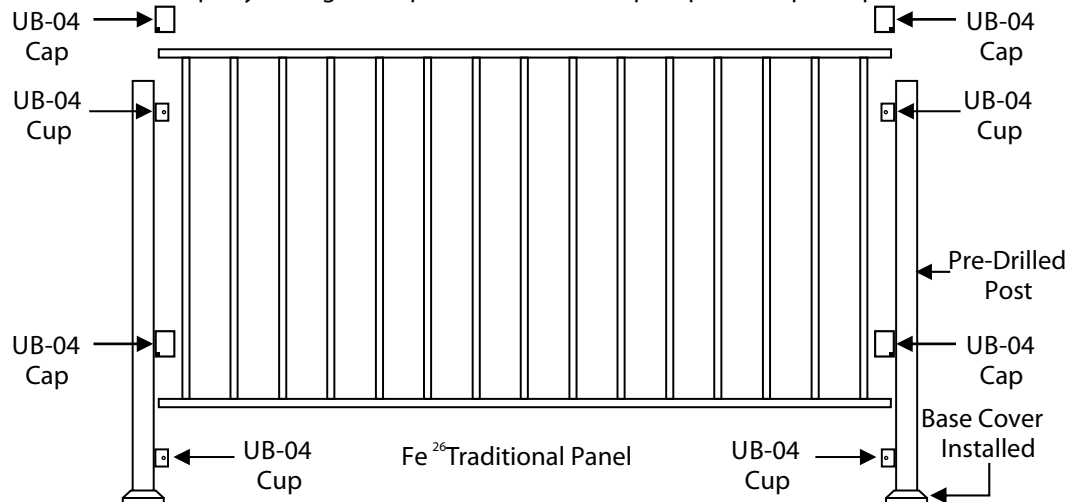

UB Bracket Hole Locations for Fe²⁶ Traditional Panel Installations with Accent Top Panel

Pre-Drilling with a 3/16" drill bit is required.

Rail Panel Height	ATP Panel Height	Pre-Drill Dimensions						
		A*	B	C	D	E	F	G
28" (711mm)	5" (127mm)	4" (102mm)	1/2" (13mm)	5/8" (16mm)	31" (737mm)	5" (127mm)	1/2" (13mm)	5/8" (16mm)
34" (864mm)	5" (127mm)	4" (102mm)	1/2" (13mm)	5/8" (16mm)	37" (940mm)	5" (127mm)	1/2" (13mm)	5/8" (16mm)
40" (1016mm)	5" (127mm)	X	X	X	X	X	X	X

- *Dimension A positions bottom edge of rail 3-3/4" (95mm) above deck surface.
- *Dimension A is measured from the bottom surface of post base.

Remove all metal shavings from deck, post base cover, post, and panel before bracket is screwed to post to prevent rust stains.

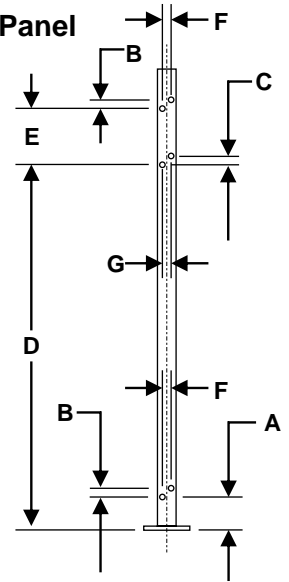

Fe²⁶ Traditional Panel with Accent Top Panel (ATP) Installation with UB-04 and UB-05

When using UB brackets rails **MUST** be cut 1/2" (13mm) shorter than the distance between posts. 1/4" (6mm) should be cut from the end of each rail to keep rail panel centered between posts.

- If rails were cut to length, file cut edges and coat with 2 coats of Fortress zinc based touch-up paint.
- Check fit of rail between installed posts.
- If using a Base Cover install it now by sliding over the top of Fe²⁶ Post.
- Slide ATP panel over the top rail of the Fe²⁶ Traditional Panel
- Secure UB brackets to Fe²⁶ Posts with provided T-25 Drive Thread Cutting Screws. Use two screws per bracket. Use low speed setting on drill.
- Drop Fe²⁶ Traditional Panel into installed UB brackets.
- Secure rails with provided set screws at each UB bracket.
- Install UB-04 Caps by sliding the cap over the UB Cup. Cap will snap into place.

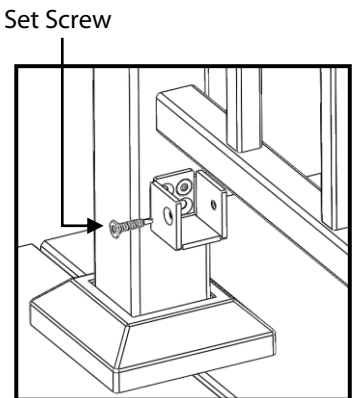
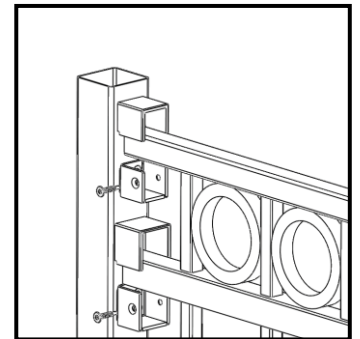
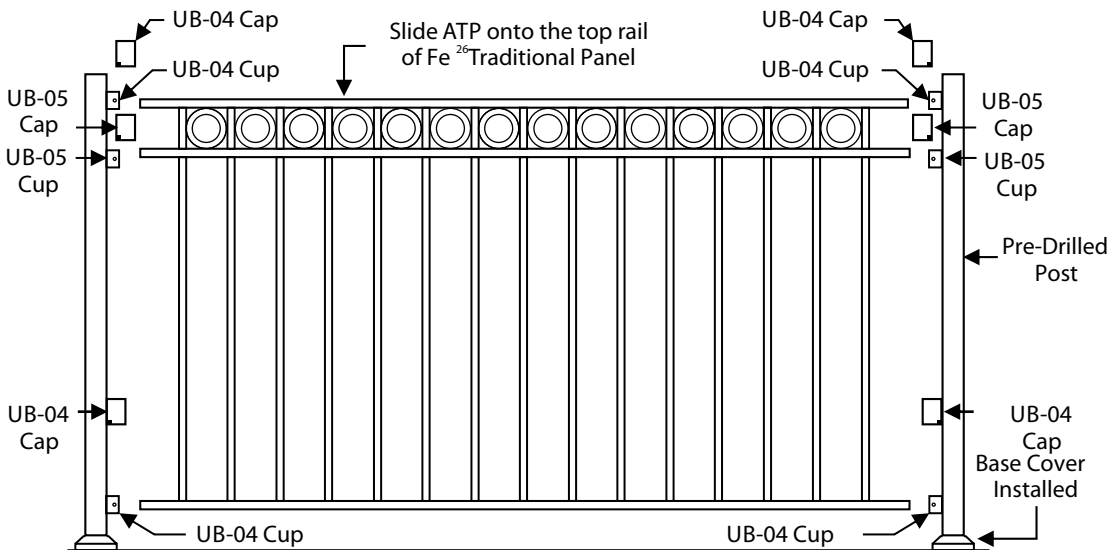

It is the responsibility of the installer to meet all code and safety requirements, and to obtain all required building permits. The deck and railing installer should determine and implement appropriate installation techniques for each installation situation. The Fortress Company nor its distributors shall not be held liable for improper or unsafe installations.

Fortress Fe²⁶ Posts must always be secured to the deck framing. Fortress Fe²⁶ Posts should never be attached to only the deck boards.

Read Instructions Completely Before Starting Installation

Note

When cutting Fortress railing, it is very important to complete the following at cut points. Not following the below steps will result in rust at the cut areas:

- Remove all metal shavings from the cut area
- File any sharp edges left by cutting. Thoroughly wipe and remove any filings, grime or dirt from the railing.
- Apply two coats of Fortress zinc based touch-up paint to the cut area. If touch up is at rail ends, allow paint to dry before connecting bracket to post.
- Be sure to remove any metal shavings from the surface of deck, patio or balcony to prevent rust on the surface.

Required Materials

UB-04, UB-04 Angle Kit, Drill, 3/16" (5mm) Drill Bit, Phillips Head Screw Driver, T-25 Driver Bit, Metal Cutting Saw, Tape Measure, Wrenches, Pencil, Speed Square, Center Punch, Support Blocks, Clamps and Hammer.

Fe²⁶ Traditional Adjustable Panels

Fe²⁶ Traditional Adjustable Panel 8' (actual length 93.5" or 2375mm) Available Heights 34" (864mm) and 40" (1016mm) Maximum rake angle 45°

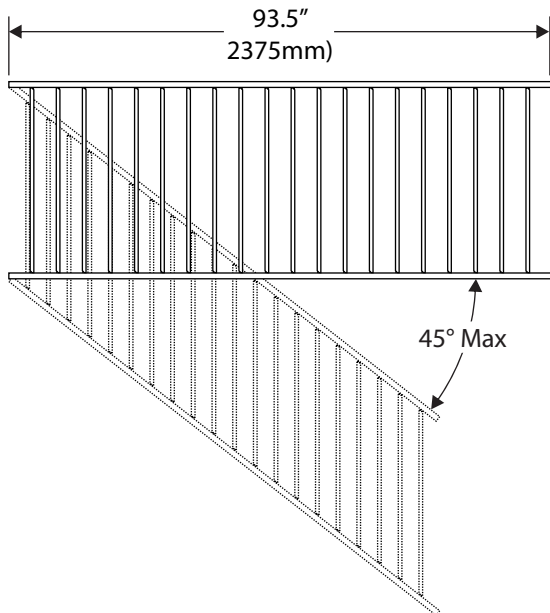

Fe²⁶ Traditional Adjustable Panel 6' (actual length 72" or 1829mm) Available Heights 34" (864mm) and 40" (1016mm) Maximum rake angle 45°

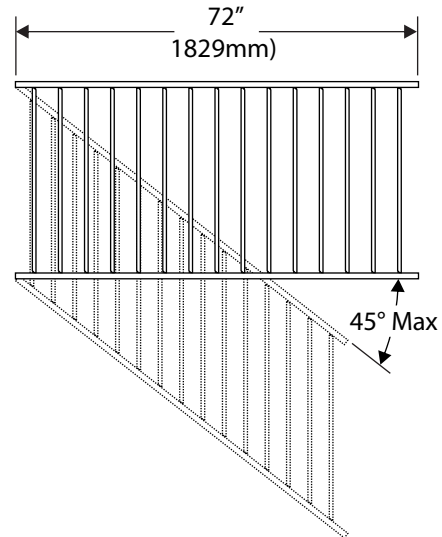

Important - Every stair installation will be different. The rise and run, post position, and post height all need to be carefully laid out before posts are permanently installed and Fortress Fe²⁶ Traditional Adjustable panels are cut.

Mount Fe²⁶ Posts*

- Wood Blocking tied to deck frame must be installed and constructed with treated dimensional lumber with a minimum thickness of 1-1/2" (38mm).
- Position the edge of Fe²⁶ Post base plate a minimum of 1/2" (13mm) from the inside edge of rim joist.
- Mount Fe²⁶ Posts at appropriate points based on panel length.
- Attach Fe²⁶ Posts with 3/8" X 3-1/2" (10mm x 89mm) Hex Head Galvanized Bolts.

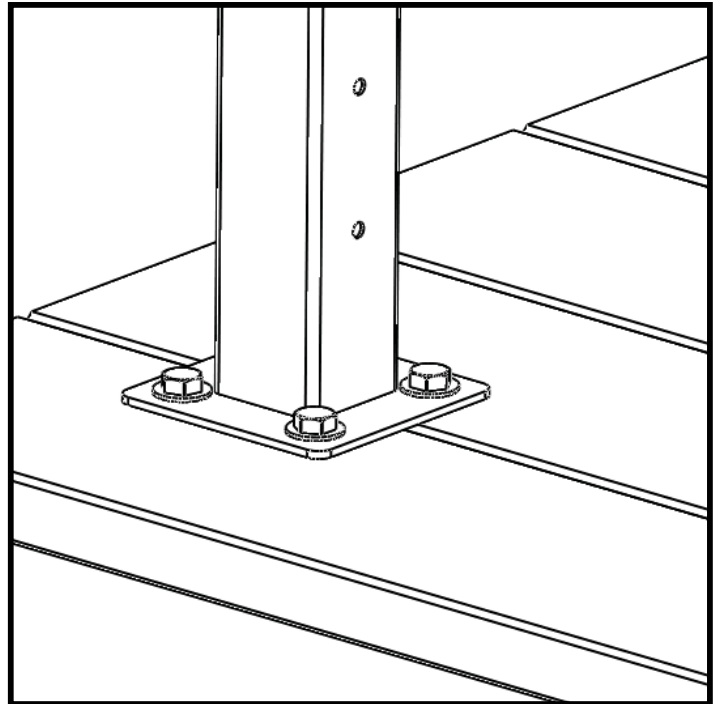
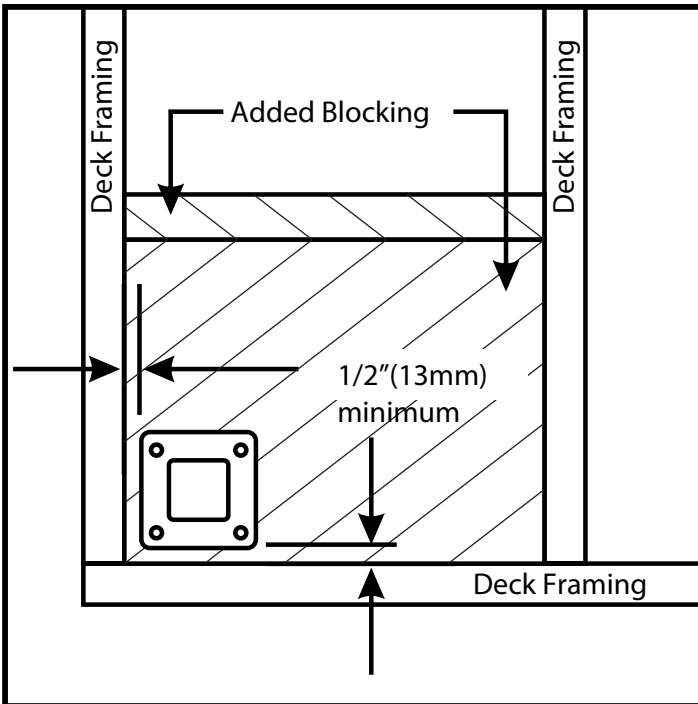

*Reference Fortress Fe²⁶ Post mounting instructions

Determine Rake and Center Panel Between Fe²⁶ Posts

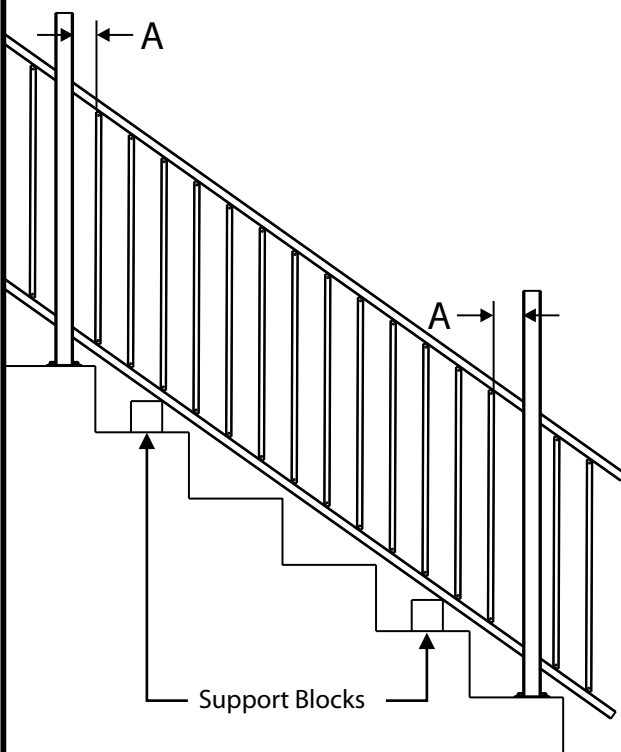

Use Fe²⁶ Adjustable Panel to determine the angle of stair installation. To do this use support blocks resting on the stair tread. Position support blocks so that the position of the bottom rail meets the spacing requirement of your building code.

Rake the panel so that the balusters run parallel with the posts. Center the balusters so that there is an equal amount of rail between the post and baluster at each end (Dimension A).

Make sure that there is enough clearance between the post and first picket to allow for the bracket.

Mark location of support blocks.

Verify Panel Position and Secure with Clamps

- Verify the position of the panel. With the help of another person, secure the panel into the correct position and secure with clamps at each end of panel.
- Place a piece of cardboard between the clamping surfaces and the surfaces of the rails and posts to protect the finish.

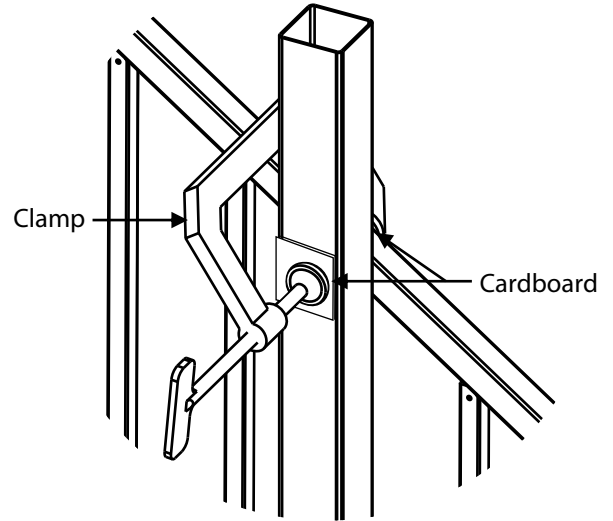
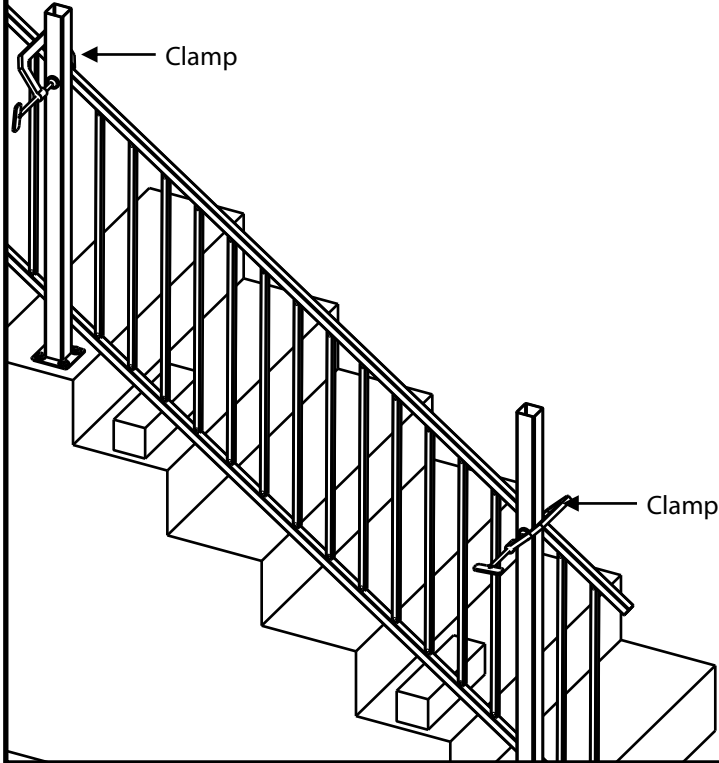

Assemble Universal Bracket Angle Kit Assembly and Mark Rail Length

- Assemble the Universal Bracket Angle Kit Assembly to the Universal Bracket Cup with supplied screws. Do not over tighten hinge pin, as it will be temporarily removed in a later step.
- Place Universal Bracket Angle Kit against post and position the cup so that it is parallel to the rail. With a pencil mark the position where the rail meets the back wall of the UB Cup on the top of the rail. With bracket in the same position mark the hole locations of the Post Plate on the post. **DO NOT DRILL HOLES AT THIS TIME.**
- Repeat this step for all four Universal Bracket Angle Bracket Locations.

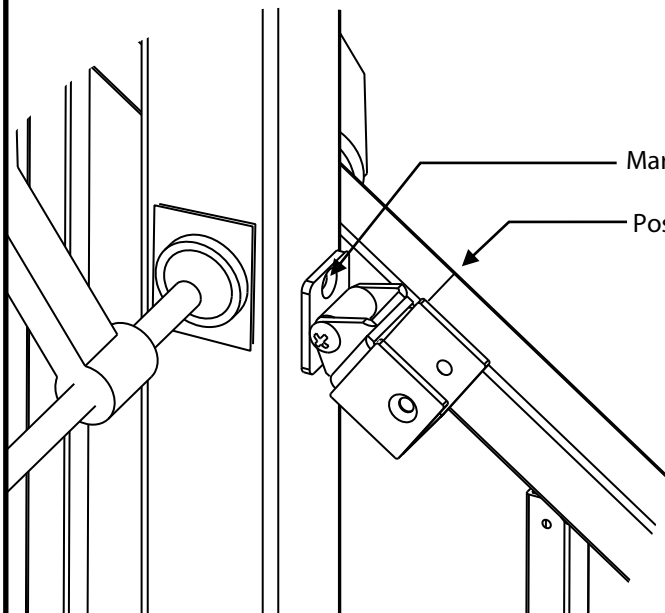

UB Angle Kit Assembly

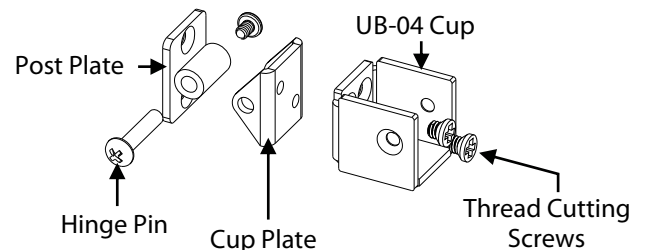

Pre-Drill and Install Universal Bracket Post Plates

- Remove c-clamps and panels.
- Mark the centerline of each post. The UB Brackets will be installed on the centerline, not the locations marked in the previous step.
- Use a center punch and hammer to mark the hole locations and pre-drill all bracket hole locations.
- Remove Hinge Pin from UB Angle Kit Assemblies.
- Attach UB Angle Kit Post Plates to post with supplied T-25 Drive Thread Cutting Screws.
- Reassemble UB Angle Kit Assemblies with Hing Pins
- **Remove all metal shavings from deck, post base cover, post, and panel before bracket is screwed to post to prevent rust stains.**

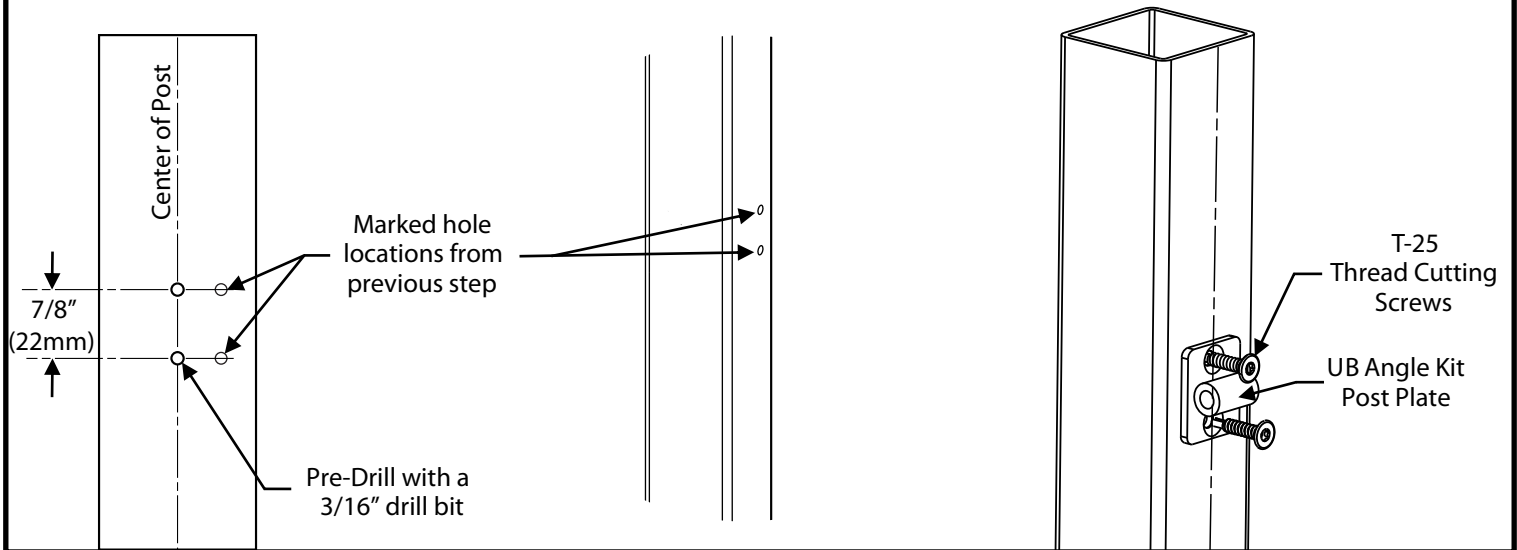

Cutting Fortress Fe²⁶ Railing Traditional Adjustable Panels

- Rake the panel back to 90° and lay on a flat surface.
- Using a metal cutting blade, cut the rail at the four cutting mark locations from previous step. It is advisable to make a practice cut on a scrap piece of rail before proceeding with the finish cuts.
- **The distances from the first picket to the ends of the rail, will be different from the top to bottom rail. The greater the angle of the steps the more visible the difference will be. This is required in order to keep balusters pickets parallel to the post.**
- File cut edges and coat with 2 coats of Fortress zinc based touch-up paint.

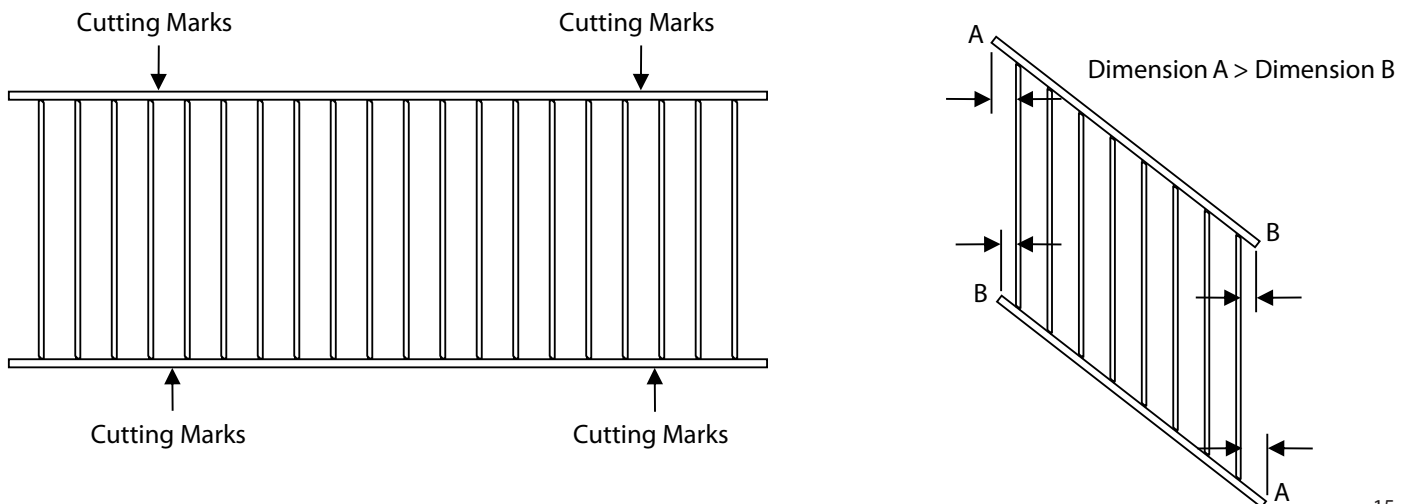

Install Panel

- Reposition support blocks.
- Position Panel so that it aligns with the brackets. Use a clamp to hold the panel in place.
- Check the fit of the panel and make any required adjustments.
- Secure panel with a set screw installed into each bracket.

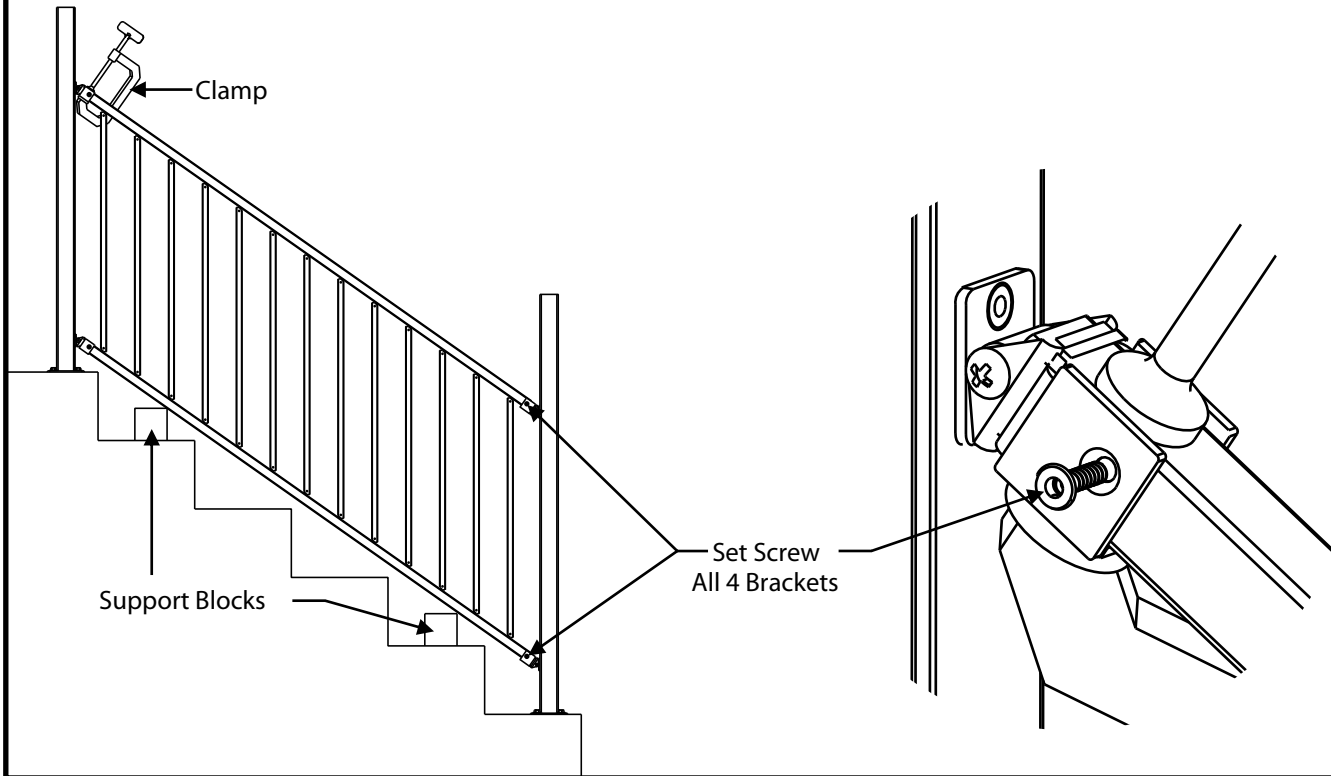

Install UB Caps

- Install UB caps by snapping the cap into place.

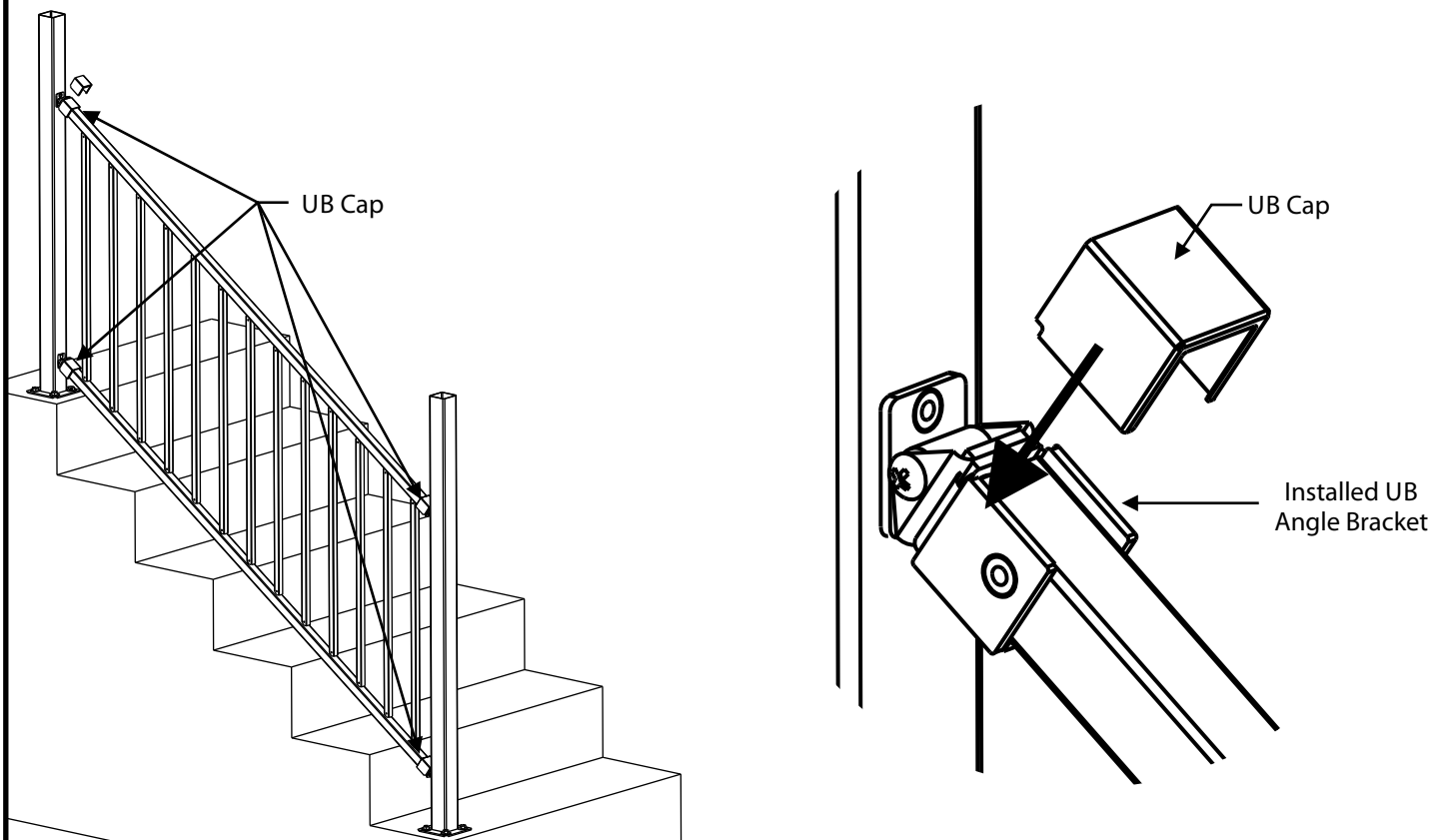

Fe²⁶

IRON RAILING SIMPLIFIED

GATES



It is the responsibility of the installer to meet all code and safety requirements, and to obtain all required building permits. The deck and railing installer should determine and implement appropriate installation techniques for each installation situation. The Fortress Company or its distributors shall not be held liable for improper or unsafe installations.

Fortress Fe²⁶ Posts must always be secured to the deck framing. Fortress Fe²⁶ Posts should never be attached to only the deck boards.

Read Instructions Completely Before Starting Installation

Note

When cutting Fortress railing, it is very important to complete the following at cut points. Not following the below steps will result in rust at the cut areas:

- Remove all metal shavings from the cut area
- File any sharp edges left by cutting. Thoroughly wipe and remove any filings, grime or dirt from the railing.
- Apply two coats of Fortress zinc based touch-up paint to the cut area. Allow paint to dry.
- Be sure to remove any metal shavings from the surface of deck, patio or balcony to prevent rust on the surface.

Required Materials

Eye Protection, Drill, 10mm Driver Bit, Metal Cutting Saw, File, Tape Measure, Pencil, Touch Up Paint and Rubber Mallet.

Fortress Fe²⁶ Gate Upright Assembly

- Maximum gate width is 48" (1219mm)
- If using Fortress Gate Kit #2, allow **3/4"**(19mm) space between Fe26Gate Uprights and posts on each side for hinges and latch.
- **Max spacing between the Fortress Fe²⁶ Gate Upright and the first baluster on each side of gate is 3-7/8"**(98mm) .
- Determine the required length of panel between Fortress Fe²⁶ Gate Uprights add 1-3/8" (35mm) to each end of rails. The extra rail length is used to secure the panel to the Fortress Fe²⁶ Gate Uprights. Balusters may need to be removed.
- Align Fortress Fe²⁶ Traditional Panel top and bottom rails with Fortress Fe²⁶ Gate Uprights. Using a rubber mallet drive Fortress Fe²⁶ Gate Uprights into the rails.
- Using a drill and 10mm driver bit install 1-10mm self drilling screw into each corner. Install the screw inside of the Fortress Fe²⁶ Gate Upright so that all screws are hidden.
- Install supplied 1-1/2" (38mm) Pressed Dome Caps on installed gate.

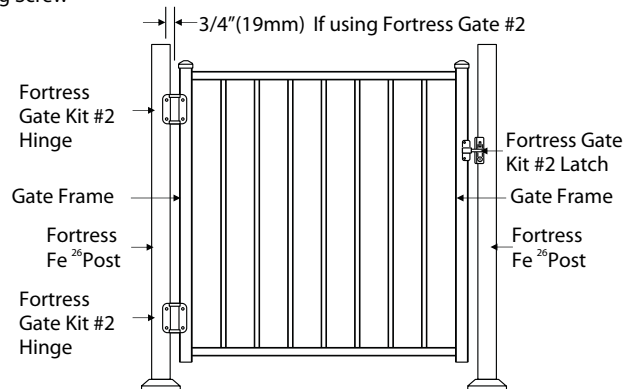
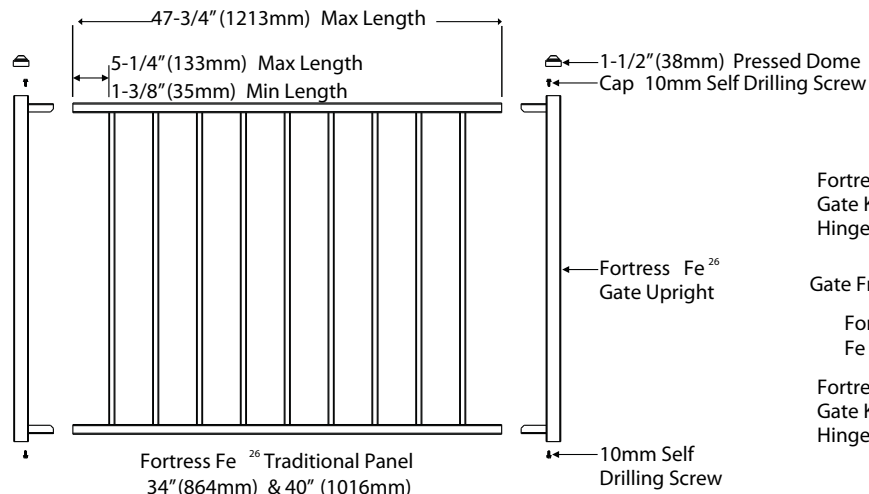
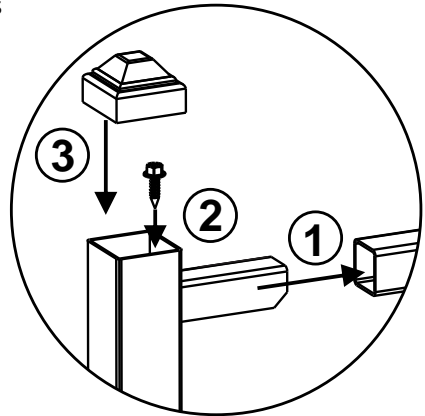

Fe²⁶

IRON RAILING

SIMPLIFIED

ACCENT TOP RAIL



Installation Instructions for Fortress Fe26 Accent Top Rail (ATR) on Traditional Panels with Universal Brackets and Fe26 Posts

It is the responsibility of the installer to meet all code and safety requirements, and to obtain all required building permits. The deck and railing installer should determine and implement appropriate installation techniques for each installation situation. The Fortress Company or its distributors shall not be held liable for improper or unsafe installations.

Fortress Posts must always be secured to the deck framing. Fortress Posts should never be attached to only the deck boards.

Note

When cutting Fortress railing, it is very important to complete the following at the cut points. Not following the below steps will result in rust at the cut areas:

- Remove all metal shavings from the cut area
- File any sharp edges left by cutting. Thoroughly wipe and remove any filings, grime or dirt from the railing.
- Apply two coats of Fortress zinc based touch-up paint to the cut area. If touch up is at rail ends, allow paint to dry before connecting bracket to post.
- Be sure to remove any metal shavings from the surface of deck, patio or balcony to prevent damaging the deck surface.

Required Materials

Saw with a ferrous metal blade, Tape Measure, Touch Up Pain, File, Caulking Gun, Fortress Epoxy, and Eye Protection

Fe²⁶ Accent Top Rail (ATR) Installation

Fortress Fe²⁶ ATR can only be installed on Fortress Fe²⁶ Traditional Panels installed with UB-04 Brackets.

- Install Fe²⁶ Traditional Panel with UB-04.
- Remove the UB-04 Caps from the top rail.
- Measure the distance between posts.
- Cut an equal distance from each end of ATR so that ATR Spacers are evenly spaced.
- Check the fit of ATR onto installed Fe²⁶ Traditional Panel.
- File any rough edges from cuts and apply zinc based touch up paint.
- **Do not apply epoxy until all ATR's are cut and tested to fit. Fortress Epoxy has a short working time.**
- Apply a quarter sized drop of Fortress Epoxy to each ATR Spacer. Follow cure times specified on epoxy packaging.
- Install ATR onto rails. Ensure that ATR is installed level with panel top rail.
- Let Fortress Epoxy cure. Do not apply any force to installed ATR for 2 hours.

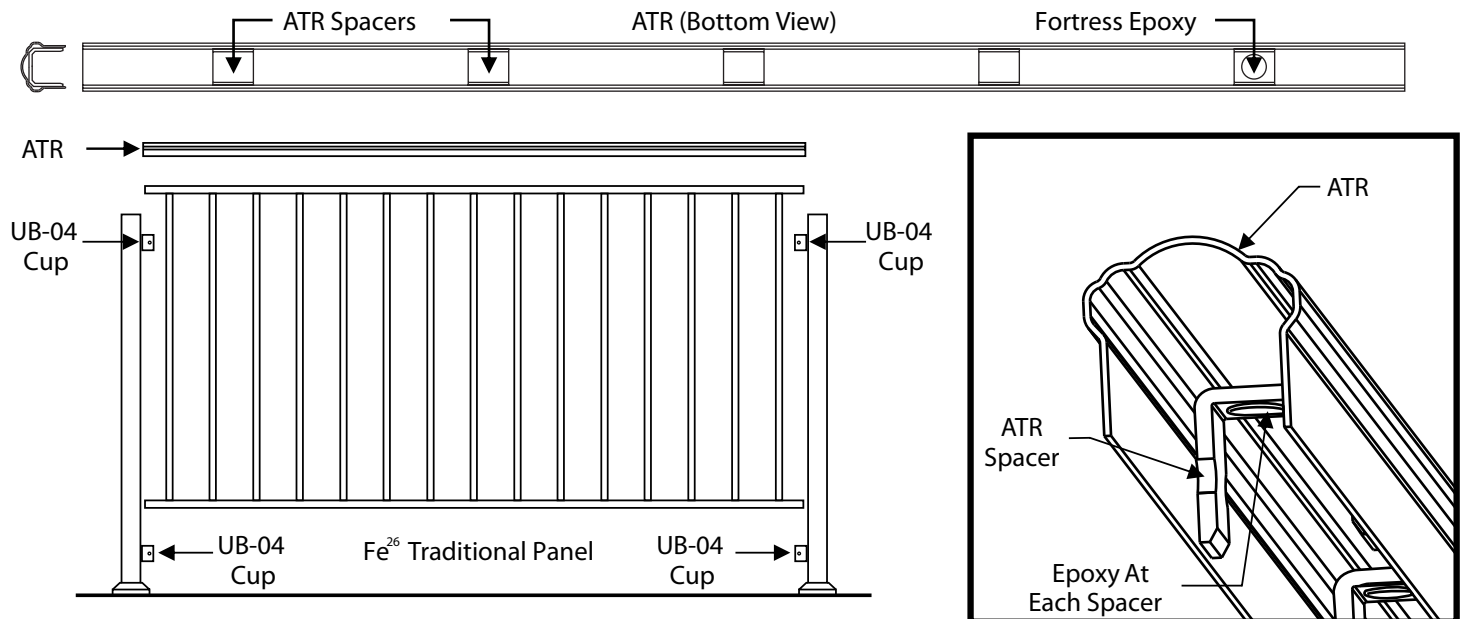

HANDRAILS SIMPLIFIED

ROUND



Installation Instructions for Fortress Round Hand Rail & Accessories

It is the responsibility of the installer to meet all code and safety requirements as well as obtain all required building permits. The installer should determine and implement appropriate installation techniques for each installation situation. The Fortress Company and its distributors shall not be held liable for improper or unsafe installations.

Read Instructions Completely Before Starting Installation

Note

Not following the below steps could result in oxidation at cut points and will void the warranty. When cutting Fortress Railing Products, complete the following at cut points:

- Cut material to length and remove all metal shavings from the cut area
- File any sharp edges left by cutting. Thoroughly wipe and remove any filings, grime or dirt from the panel.
- Apply two coats of Fortress touch-up paint to the cut area.
- Be sure to remove any metal shavings from the work surface to prevent oxidation on the surface.

Required Materials

Drill, 5/32" Drill Bit, T-25 Driver, Tape Measure, Speed Square, Level, Fortress Epoxy, Metal Cutting Saw, File, Brush or Rags, Cardboard, Fortress Zinc Based Touch-Up Paint.

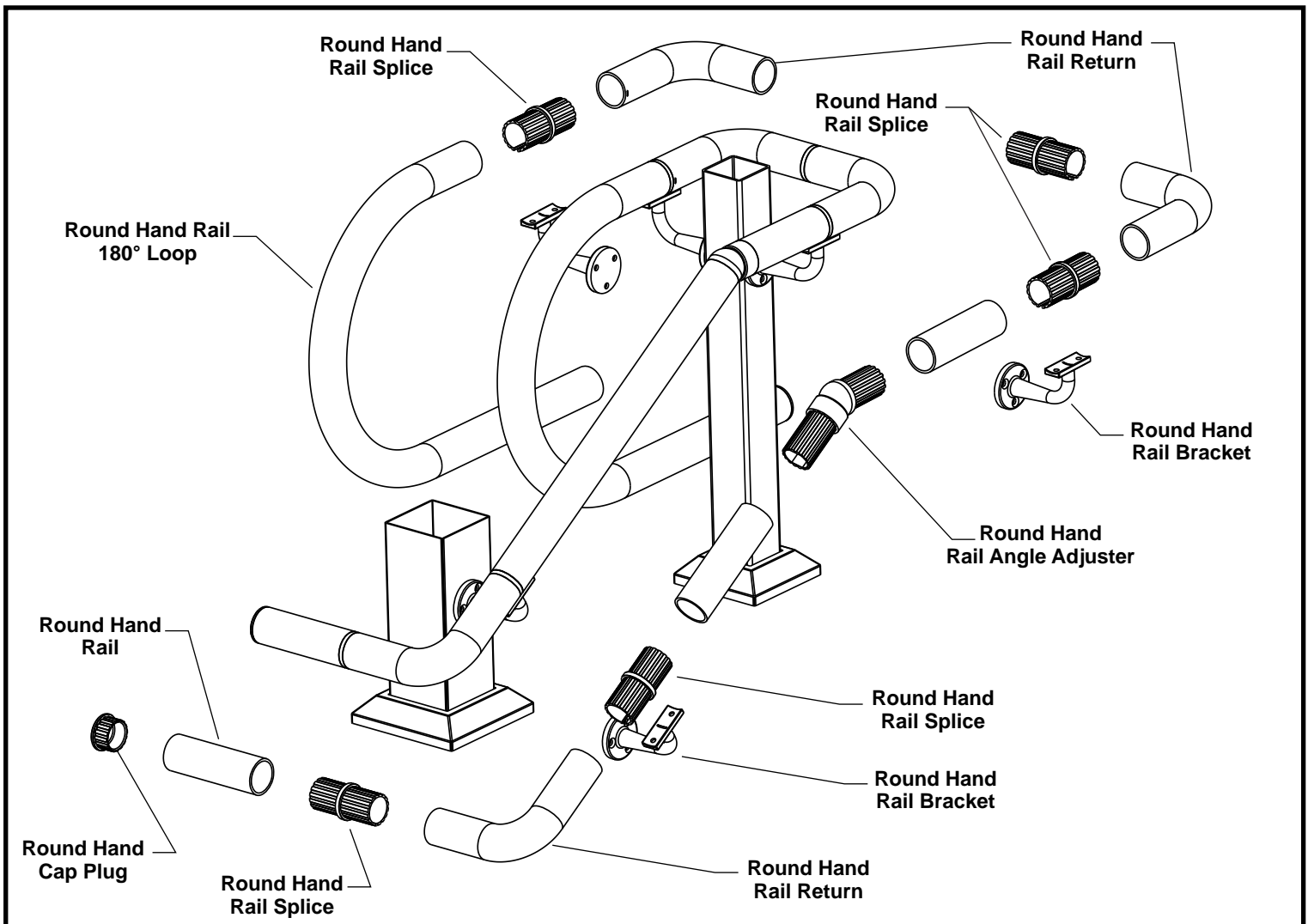

Round Hand Rail Bracket

Used to attach Round Hand Rail Components to Posts and Vertical Wall Surfaces.

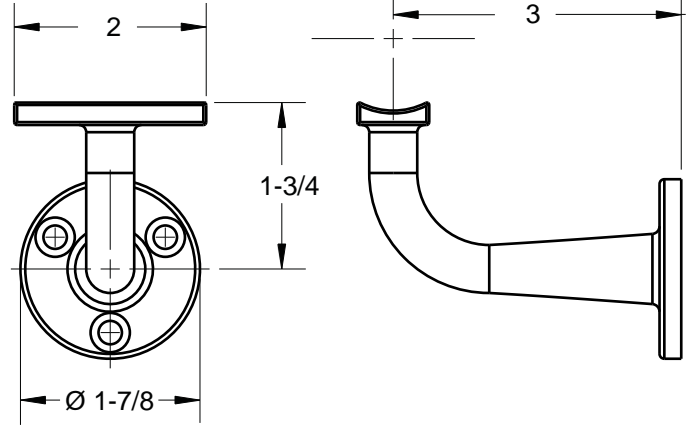
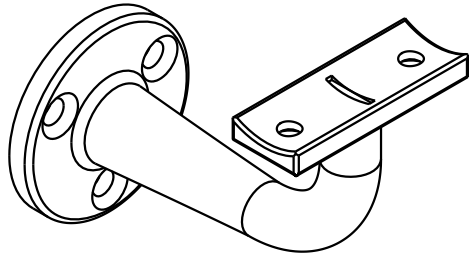

Round Hand Rail

Used to create Handrail Sections between brackets.

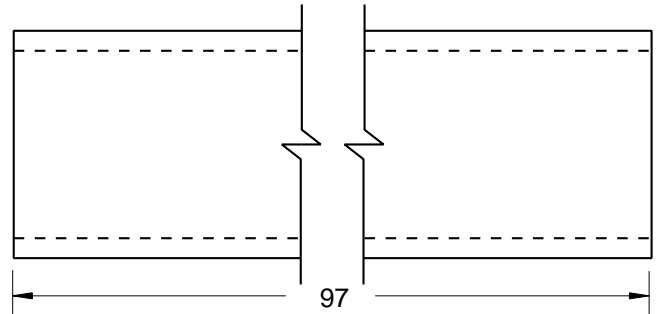
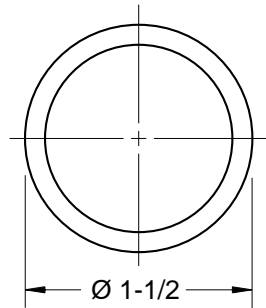

Round Hand Rail Splice

Used to join mating parts of the Round Hand Rail System that do not already have ribbed insert sections.

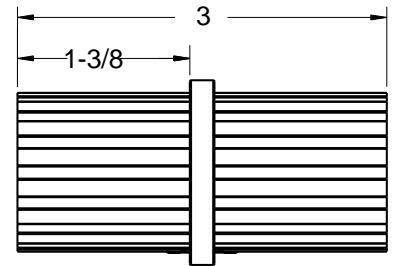
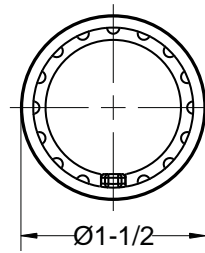
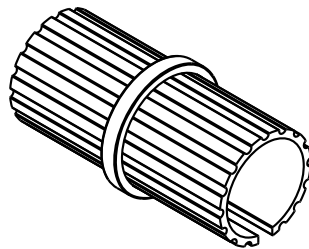

Round Hand Rail Return

Used to create corners and continuous rails around posts.

The Round Hand Rail Return has two different straight lengths 4-5/8" (**marked with a notch**) and 5-5/32" that allow installer to create a continuous Hand Rail around 2" and 3" Posts without modifying the Round Hand Rail Return.

For a continuous wrap around a 2" Post butt the two 4-5/8" lengths together.

For a continuous wrap around a 3" Post butt the two 5-5/32" lengths together.

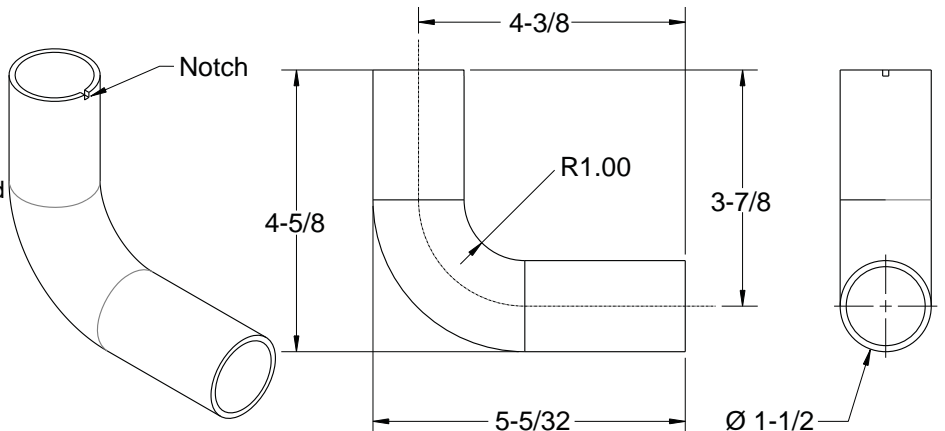

Round Hand Rail Cap Plug

Used to cap open ends of the Round Hand Rail System.

Can Also be used to terminate a Round Hand Rail into a vertical wall surface by pre-drilling at the molded center point and securing to wall surface with a screw.

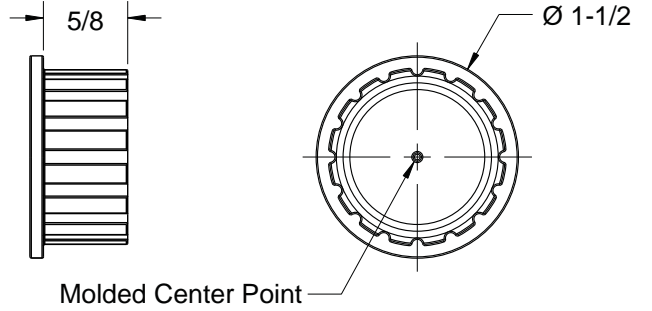
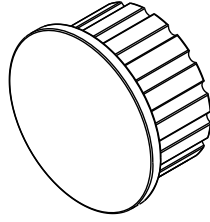

Round Hand Rail Angle Adjuster

Allows for smooth transitions between Hand Rail section with changes in elevation.

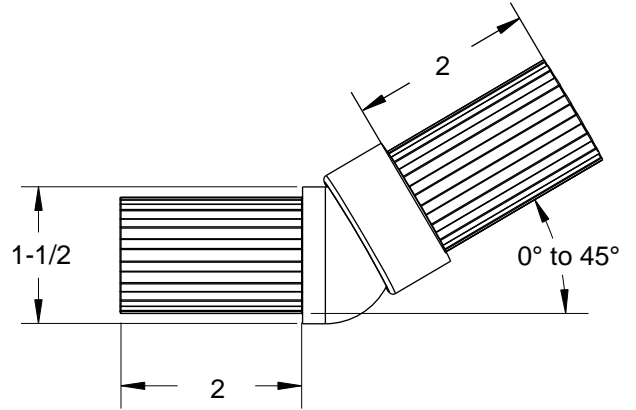
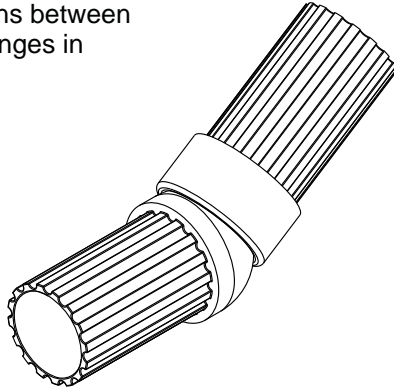

Round Hand Rail 180° Loop

Used to terminate handrails into posts.

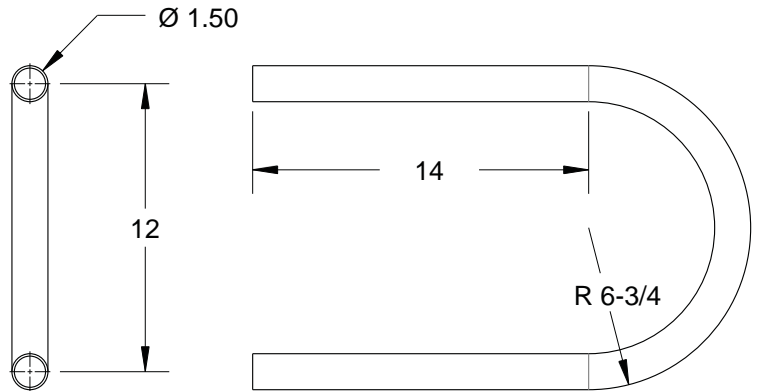
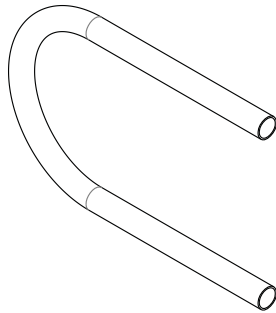

Fortress Pro-Poxy Kit (250ml)

2 part epoxy used to join Round Hand Rail Components. Use a standard chalking gun to dispense. Replacement Static Mixers sold separately.

Product Cures Quickly. Do not apply until all parts are tested to fit.

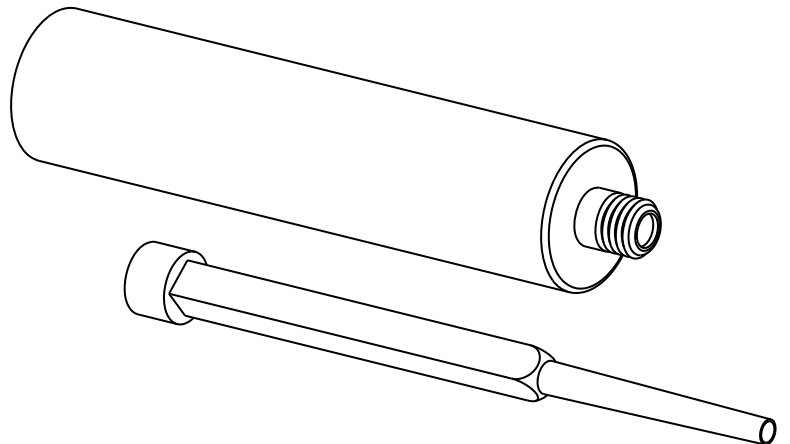
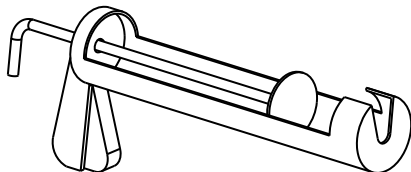



Marketed and Distributed by:

