



Installation Guide For:



Call 1-800-335-5909 for Installation Support
M - F 7:30 a.m. - 6:00 p.m. CST

**This Packet MUST Accompany
Materials To Job Site**

Read all instructions before beginning installation

Extra Screws Included



**INSTALLATION VIDEOS
AVAILABLE ONLINE:**

**WWW.DEKPROMFG.COM/
INSTALLATION.HTML**



Table of Contents

Level Railing	Pg. 2 - 6
Prestige Quick Jig	Pg. 8
Stair Railing	Pg. 10 - 15
Multi-Angle Railing	Pg. 18 - 23
Secondary Handrail	Pg. 26 - 30
Gate Kit Assembly	Pg. 32 - 35
Tri-Rail Design	Pg. 38 - 39
Drink Rail Bracket	Pg. 40
Cable Railing	Pg. 42
Glass Railing	Pg. 43





DekPro™ Prestige Textured Aluminum Railing Systems

Level Railing



DekPro™ Prestige Aluminum Rail System Level Railing Installation Instructions

Level Railing Installation Guide

- Please read all instructions completely before starting any installation of DekPro™ Prestige Railing Systems.
- **SAFETY:** Always be safe and follow all instructions when using power tools and always wear eye protection!
- Proper blocking must be in place before mounting posts.
- Rail Sections come in nominal 6ft & 8ft lengths. (Actual rail lengths are 70" and 96.75" respectively).
- Residential default finished rail height when using DekPro™ bracket installation Quick Jig is 38" and Commercial is 42".
- Posts are available in RESIDENTIAL rated (3" & 4" posts w/ flange and 4" Sleeve) and COMMERCIAL (3" post w/ flange)
- DekPro™ Prestige Railings should be installed using good building principles in accordance with local building codes and the installation guidelines. Consult your local building code official and check all code requirements before installing railings. DekPro™ or its distributors shall not be held liable for improper or unsafe installations.
- It is the responsibility of the installer to obtain all required building permits and meet code requirements.
- DekPro™ Prestige Railing has been tested by ATI and meets testing standards for IRC and IBC construction codes AC273. Test report CCRR # 0233.
- For questions contact Absolute Distribution Inc., U.S. national distributor for DekPro™ Prestige Railing Systems at 800-335-5909 or www.AbsoluteDist.com

Recommended Tools for Installation

- Level
- Mallet / Hammer
- Speed Square
- Cordless Drill / Impact driver
- Quick clamp grips
- Pencil
- Tape Measure
- Miter saw with high tooth count carbide blade
- 13/64" drill bit (Optional)
- T30 Torx screwdriver bit
- #2 Phillips - Long Bit

Installation Videos



INSTALLATION VIDEOS
AVAILABLE ONLINE:

[WWW.DEKPROMFG.COM/
INSTALLATION.HTML](http://WWW.DEKPROMFG.COM/INSTALLATION.HTML)

Rail Profiles & Hardware

Rail Components

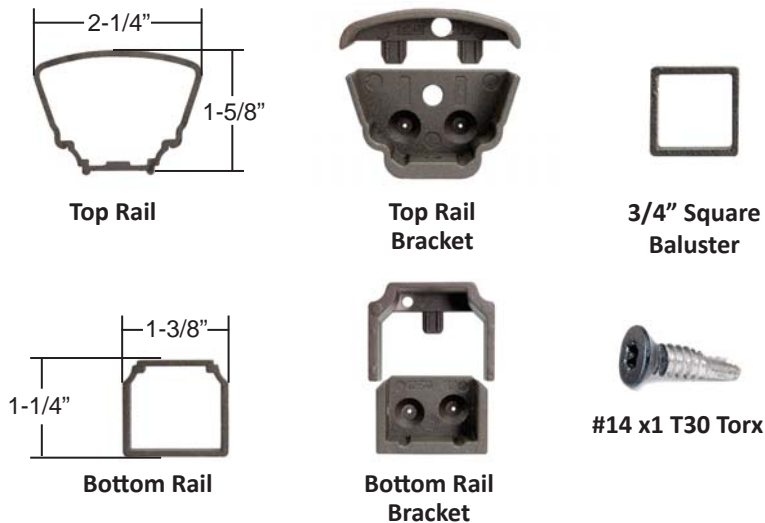

Foot Block



All fasteners for attaching brackets to posts and rails are packaged with rail kits. Fasteners for post base are NOT provided due to varying installation circumstances. #14 T30 Torx, self-drilling screws included. 2 screws for each bracket attachment and 1 screw for securing rail profile to the bracket. Foot block assembly has 1 self-drilling screw for the foot block and two for the shoe. All screws are color matched to the rail. Use a T30 Torx screwdriver bit for a sure fit.

DekPro™ Prestige Aluminum Rail System Level Railing Installation Instructions

Post Placement & Installation

Step 1: Layout

Lay out post placement.
If stairs are involved, it may be beneficial to start with post placement at top of stair run.

Ensure proper blocking is in place before mounting posts.

Actual Railing Lengths:

- 70" for 6' rail
- 96-3/4" for 8' rail

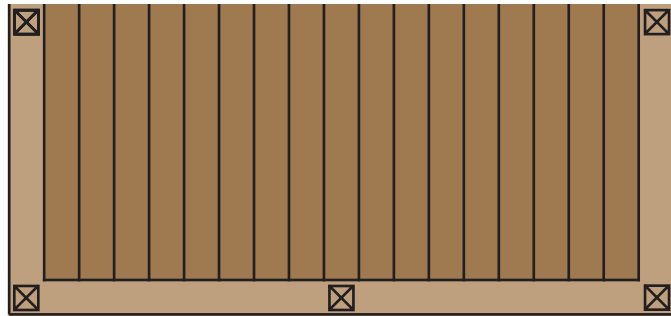

Step 2: Mount Post

- Set post in place and mark four mounting holes.
- Pre-drill holes for mounting hardware, then fasten post with mounting hardware (not included). See below for mounting options.
- Check that post is plumb and shim if necessary (shims included).
**Note: Optional Quick Jig can be used to plumb posts using the attached 2 way level.*
- For 4" sleeve - Slide sleeve over existing wood 4x4 and furr-out as necessary.



Mark and Pre-drill Holes



Fasten Post to Deck Surface



Post Mounting Options

Surface Mount using Carriage Bolt

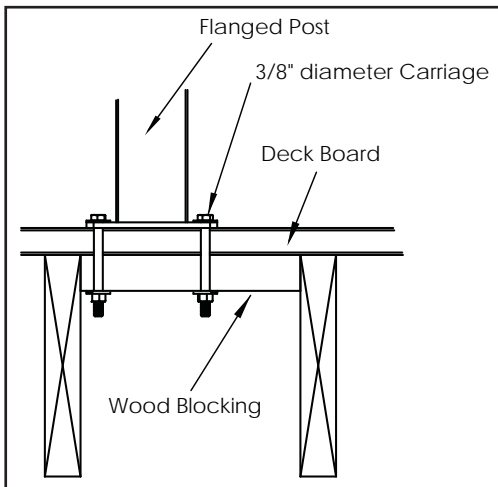

Surface Mount using Lag Bolt

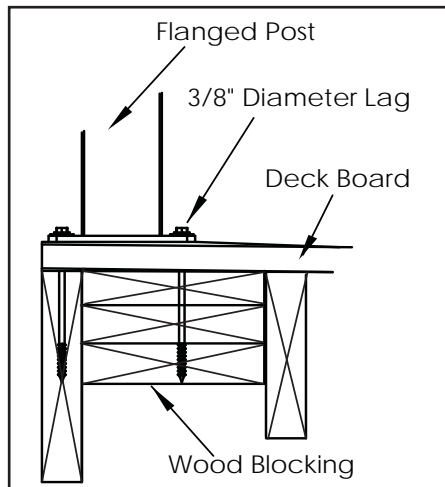

Surface Mount using Concrete Anchor

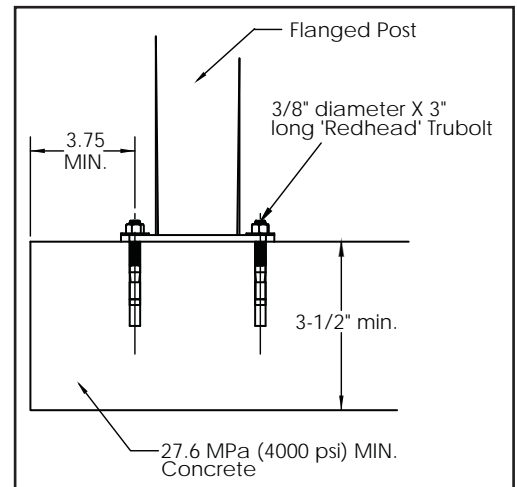

DekPro™ Prestige Aluminum Rail System Level Railing Installation Instructions

Level Rail Installation

Step 3a: Attaching Brackets to Post

Standard Installation - Using Prestige Quick Jig

- Clamp Prestige™ Quick Jig to post.
- Insert brackets into the Quick Jig
- Use T30 Torx self-drilling screws to fasten bracket.
 - Pre-drill holes if desired
- Remove Quick Jig.

**Note: Quick Jig is also used to plumb posts using the attached 2 way level.*

**Note: Default finished rail height will be 38" for residential and 42" for commercial when using Prestige™ Quick Jig with 3-1/8" foot block.*



Clamp Quick Jig



Fasten Bracket

Step 3b: Attaching Brackets to Post

Standard Installation - Without Quick Jig

Bottom Rail Bracket Installation:

- Measure up 2-1/2" from the top of the base plate and mark a horizontal line.
- Center the bracket on the post with the bottom edge of the bracket at the line you marked previously
- Use T30 Torx self-drilling screws to fasten bracket. (Pre-drill holes if desired)

**Note: Installation for bottom bracket is the same for 38" rail and 42" rail using the 3-1/8" foot block.*



Measure up 2-1/2" from top of base plate



Center bracket and attach to post



Measure up 35-3/4" from top of base plate (38" rail example).



Center bracket and attach to post

Top Rail Bracket Installation:

- **For 38" Rail:** Measure up 35-3/4" from the top of the base plate and mark a horizontal line
- **For 42" Rail:** Measure up 39-3/4" from the top of the base plate and mark a horizontal line
- Center the bracket on the post with the bottom edge of the bracket at the line you marked previously
- Use T30 Torx self-drilling screws to fasten bracket. (Pre-drill holes if desired)

**Note: Default finished rail height will be 38" for residential and 42" for commercial using standard installation procedure with 3-1/8" foot block.*

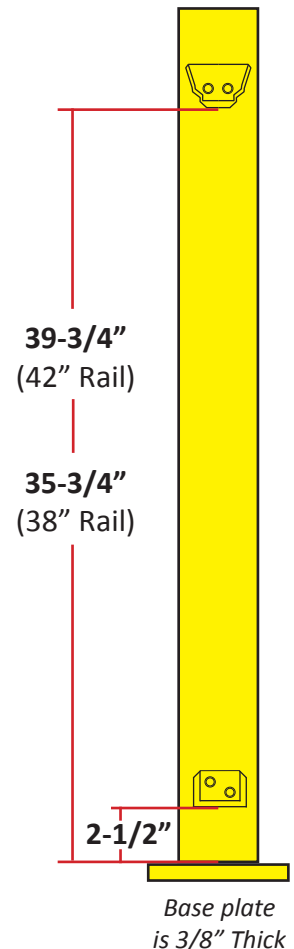

DekPro™ Prestige Aluminum Rail System Level Railing Installation Instructions

Level Rail Installation (Continued)

Kit Includes:

- 1 - Top Rail (Baluster connectors installed)
 - 1 - Bottom Rail (Baluster connectors installed)
 - 2 - Bottom Rail Brackets
 - 2 - Top Rail Brackets
 - 1 - Foot Block Rail Support Kit
 - Aluminum Balusters
 - 15 Balusters with 6' kit
 - 21 Balusters with 8' kit
- (All hardware is included to complete rail kit assembly)*



Step 4: Cut Rails to Size

- Measure distance from inside of post to inside of post and deduct 1/4" from each end of rail. (1/4" deduction accounts for rail bracket wall thickness)
- Measure bottom rail ensuring equal and maximum spacing from end of rail to the first baluster on both ends of the bottom rail.
- Cut bottom rail with a high tooth count carbide blade.
- Repeat previous steps when measuring and cutting the top rail. **All cut ends must be painted to prevent oxidation.**

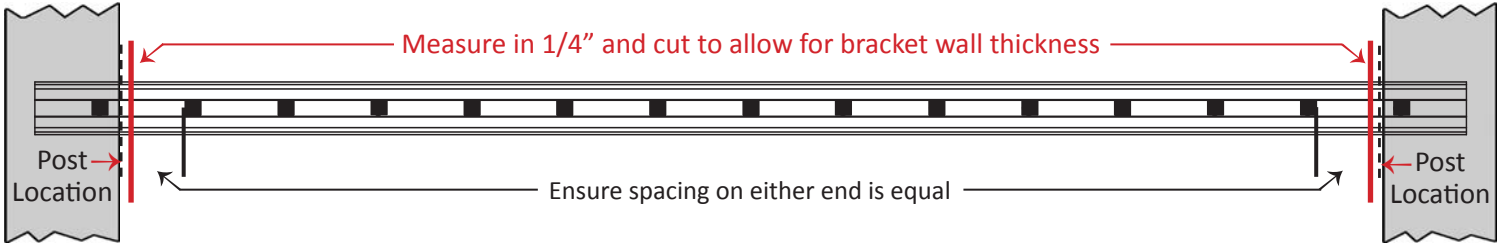

Step 5: Assemble Rail Kit

A.) Insert balusters onto the baluster connectors of the bottom rail. Insert first two balusters from one end of top rail and progressively work your way to the other end to attach top rail to balusters (rail packaging comes with a cardboard rail comb to help align and speed up rail kit assembly). **B.)** After all connectors are engaged with the balusters a ratchet strap can be used to pull rails together tightly or use a rubber mallet with a wood board (minimum 12" length) to distribute load evenly and to fully seat balusters into rails.

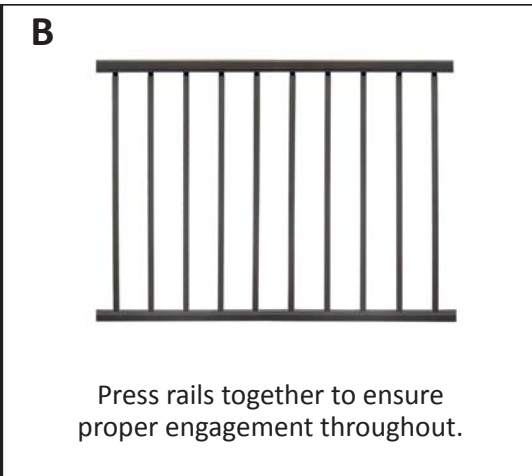
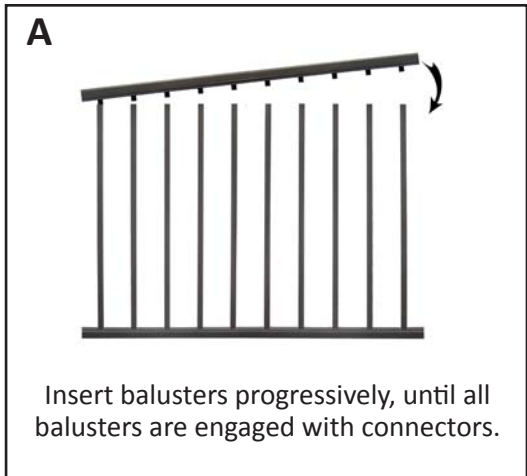

* DekPro™ boxes come with a cardboard rail comb to help align and speed up rail kit assemblies

DekPro™ Prestige Aluminum Rail System Level Railing Installation Instructions

Level Rail Installation (Continued)

Step 6a: Mounting Foot Block to Rail

- Center and install foot block to bottom rail with 1 ea. self-drilling screw.
- Center foot block shoe between posts and install to deck surface using 2 ea. screws.

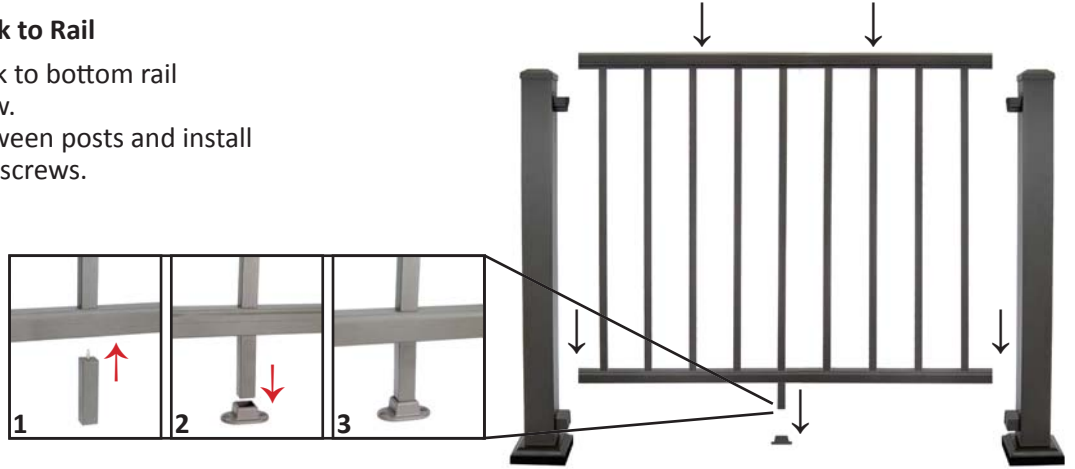

Step 6b: Set Assembled Rail into Brackets

Set railing into brackets and secure with screws. Install top bracket screw first to pull rail down tightly into bottom brackets. **Use 1 Screw per bottom bracket to secure rails in place.**

**Note: Set screw gun on "Screw" mode not "Drill" mode.*

IMPORTANT:
Bottom Bracket has 2 holes but only requires the use of 1 screw to secure rail.

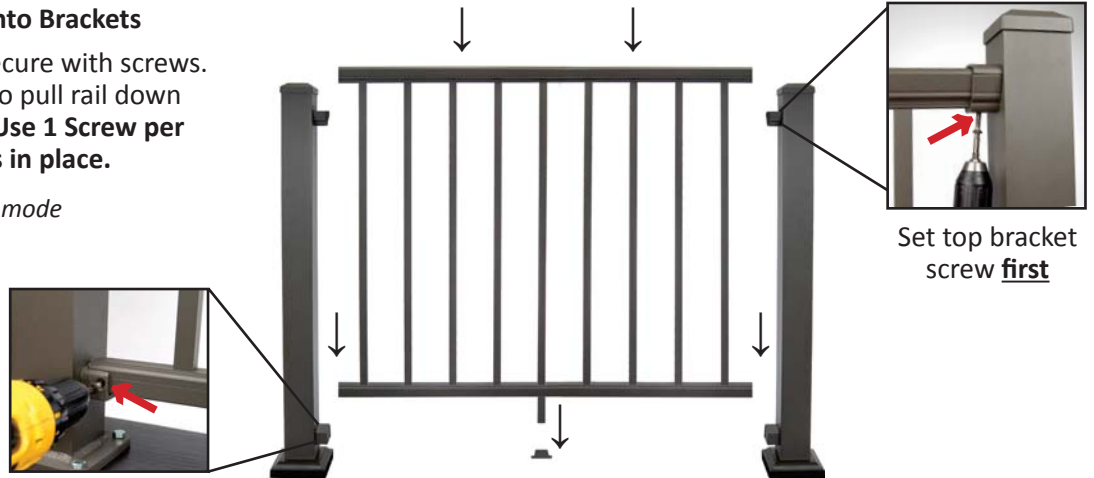

Step 7: Finish the Rail

Install rail bracket covers using a mallet/hammer and wood block to seat the bracket covers properly onto the bracket (Remove post cap if installed).

IMPORTANT! - Bracket cover must be tapped straight down. Bracket cover tabs may break if driven down at an angle.

Install post cap and 2 pc. skirt.

Installed Cap



Installed Skirt



IMPORTANT!



DekPro™ Prestige Textured Aluminum Railing Systems

Quick Jig Guide



Quick Jig Overview

DekPro™ Prestige Quick Jig

The Quick Jig rail guide allows you to locate and fasten rail brackets to the post for level railing, eliminating the need to measure. Quick Jig can also be used to plumb posts using the attached 2-way level.



Quick Jigs are available for both 3" & 4" flanged posts and 4" post sleeves.

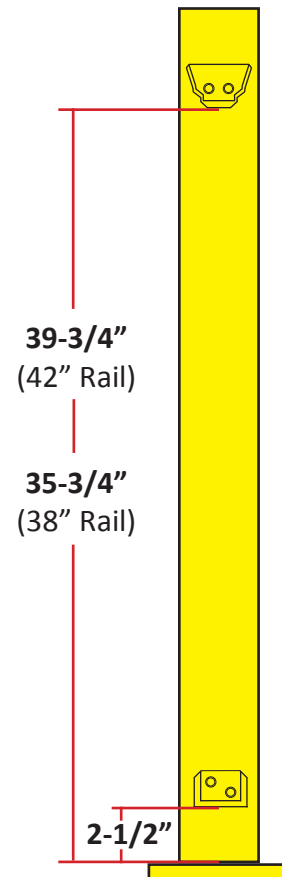
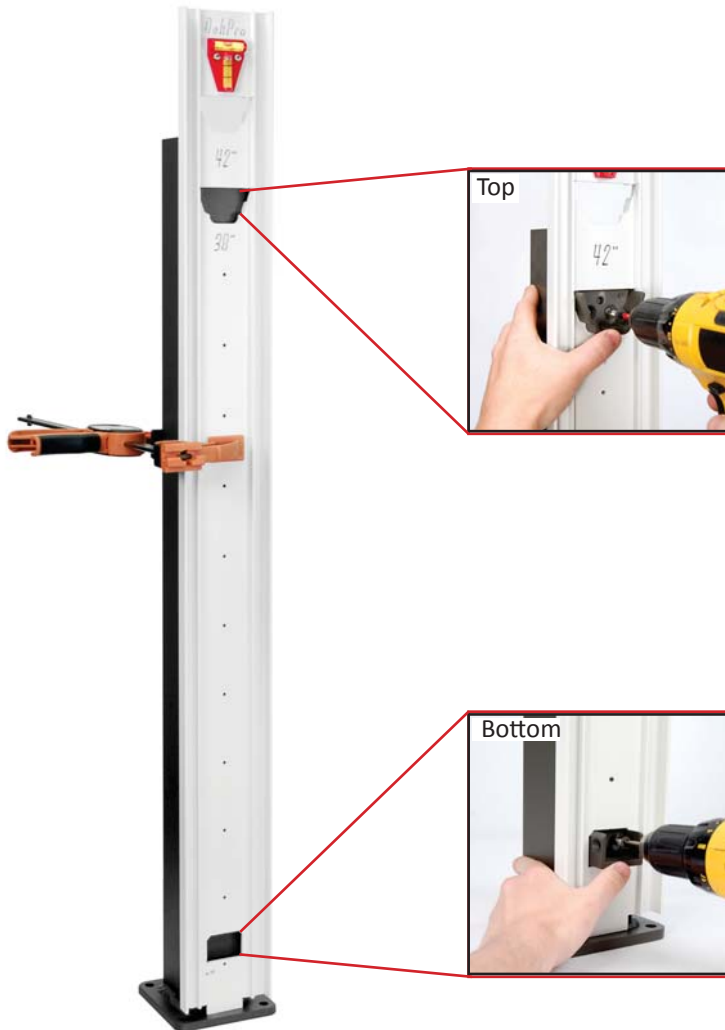

Place jig up against post to locate brackets. A clamp can be used to secure the jig to the post.



Place bracket into the opening of the Quick Jig. (Pre-drill holes if desired).



Secure bracket onto post with 2 ea. self-drilling screws. Remove jig from post.

DekPro™ Prestige Textured Aluminum Railing Systems

Stair Railing



DekPro™ Prestige Aluminum Rail System Stair Railing Installation Instructions

Stair Railing Installation Guide

- Please read all instructions completely before starting any installation of DekPro™ Prestige Railing Systems.
- **SAFETY:** Always be safe and follow all instructions when using power tools and always wear eye protection!
- Rail sections come in nominal 6ft & 8ft lengths. (Actual rail lengths are 70" and 96.75" respectively).
- Posts are available in RESIDENTIAL rated (3" & 4" posts w/ flange and 4" Sleeve) and COMMERCIAL (3" post w/ flange)
- Proper blocking must be in place before mounting posts.
- Stair rails are rackable up to 40°
- DekPro™ Prestige Railings should be installed using good building principles in accordance with local building codes and the installation guidelines. Consult your local building code official and check all code requirements before installing railings. DekPro™ or its distributors shall not be held liable for improper or unsafe installations.
- It is the responsibility of the installer to obtain all required building permits and meet code requirements.
- DekPro™ Prestige Railing has been tested by ATI and meets testing standards for IRC and IBC building codes AC273. ATI test report CCRR # 0233.
- For questions contact Absolute Distribution Inc., U.S. National Distributor for DekPro™ Prestige Railing Systems, at 800-335-5909 or www.AbsoluteDist.com

Recommended Tools for Installation

- Level
- Mallet / Hammer
- Speed Square
- Cordless Drill / Impact driver
- Quick clamp grips
- Pencil
- Tape Measure
- Miter saw with high tooth count carbide blade
- T30 Torx screwdriver bit
- 13/64" drill bit (Optional)

Installation Videos



INSTALLATION VIDEOS
AVAILABLE ONLINE:

[WWW.DEKPROMFG.COM/
INSTALLATION.HTML](http://WWW.DEKPROMFG.COM/INSTALLATION.HTML)

Rail Profiles & Bracket Hardware

Top Rail Bracket Overview

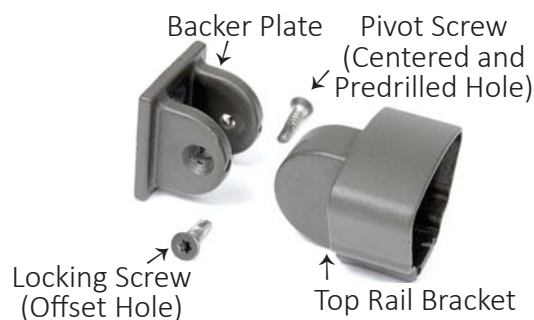

Bottom Rail Bracket Overview

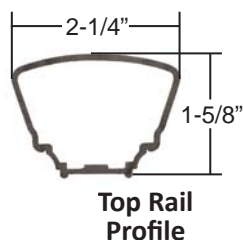
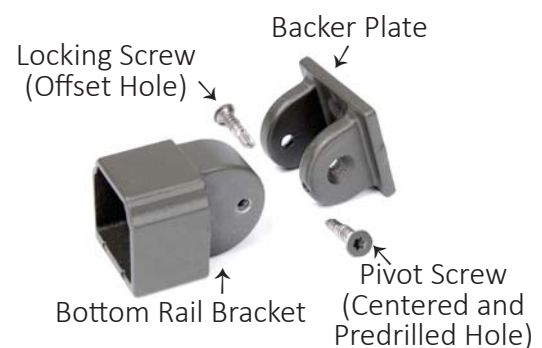

All fasteners for attaching brackets to posts and rails are included in box kit. Fasteners for post base are **NOT** provided due to varying installation circumstances. #14 T30 Torx, self-drilling screws included with each bracket, 2 screws for backer plate attachment, 1 for pivoting screw, 1 for locking screw and 1 for securing bracket to rail. Use a T30 Torx screwdriver bit for a sure fit.

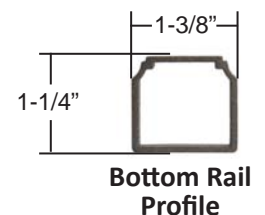

DekPro™ Prestige Aluminum Rail System Stair Railing Installation Instructions

Post Placement & Installation

Step 1: Layout

Lay out post placement.
Stair rail installation must start with post placement at top of stair run.

Ensure proper blocking is in place before mounting posts.

Actual Railing Lengths:

- 70" for 6' rail
- 96-3/4" for 8' rail



Mark and Pre-drill Holes



Fasten Post to Deck Surface

Start Here

Top of Stairs

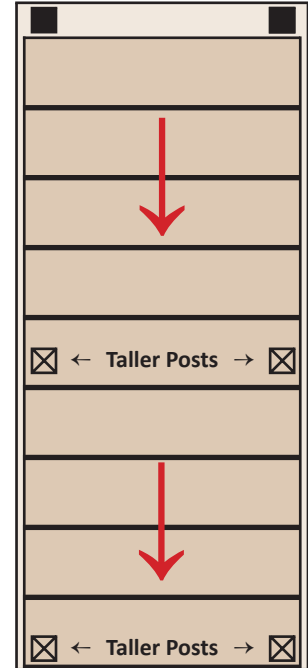

Bottom of Stairs

Step 2: Reference Diagram

Step 2: Mount Posts

- Start with top post (■). Set into place and mark four mounting holes.
- Pre-drill holes for mounting hardware, then fasten post with mounting hardware (Not Included). See below for mounting options.
- Check that post is plumb and shim if necessary (shims included).
**Note: Optional Quick Jig can be used to plumb posts using the attached 2 way level.*
- After top posts (■) are installed, temporarily place lower post(s) (⊗) on tread to allow for adjustment to ensure proper baluster spacing between post and baluster. Lower posts may need to be removed to allow for lower bracket installation (Ref. Step 5) and/or trimming of post to appropriate height. Lower posts must be taller to allow for flexible post placement.
- Once rails are set all posts can be permanently mounted.
- For 4" sleeve - Slide sleeve over existing wood 4x4 and furr-out as necessary

Post Mounting Options

Surface Mount using Carriage Bolt

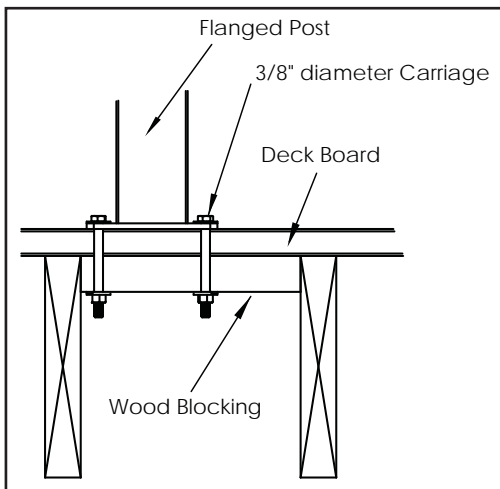

Surface Mount using Lag Bolt

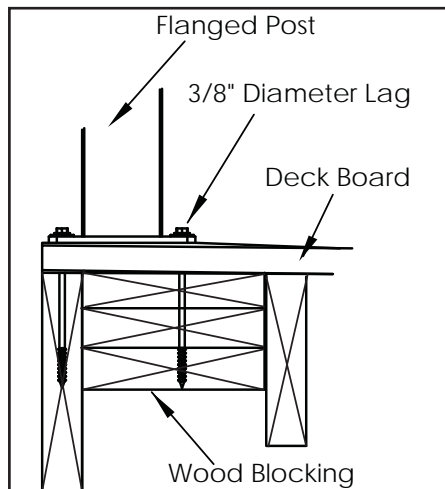

Surface Mount using Concrete Anchor

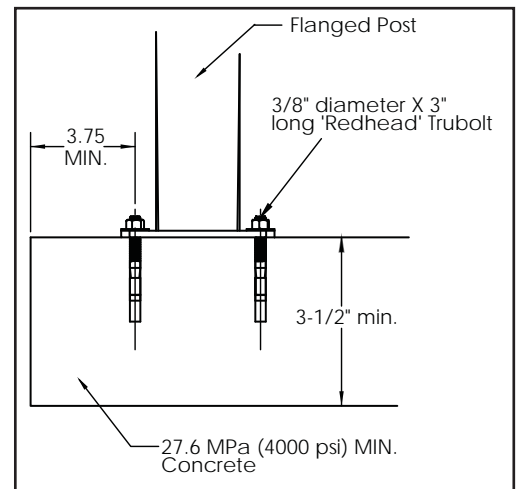

DekPro™ Prestige Aluminum Rail System Stair Railing Installation Instructions

Stair Rail Kit

Kit Includes:

- 1 - Top Rail (Pre-Slotted for Balusters)
- 1 - Bottom Rail (Pre-Slotted for Balusters)
- 2 - Bottom Rail Brackets
- 2 - Top Rail Brackets
- Aluminum Balusters
 - 15 Balusters with 6' kit
 - 21 Balusters with 8' kit

(All hardware is included to complete rail kit assembly)

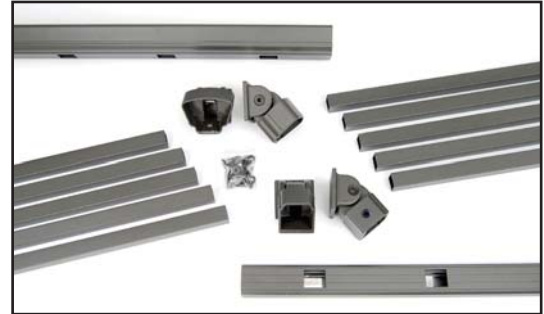

Stair Rail Installation

Step 3: Place Post Skirt

Slide post skirt into place at base of top post to ensure proper clearance of lower rail and bracketry.

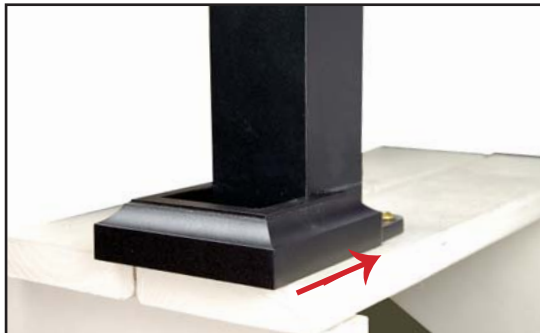

Step 5: Baluster to Post Spacing

Place a baluster into hole closest to each post. Ensure equal spacing from baluster to post at top and bottom of stair. Allow minimum 3" and maximum 4" space between post and baluster to accommodate bracket. Adjust bottom post for 3" - 4" spacing, then bottom post can be permanently fastened.

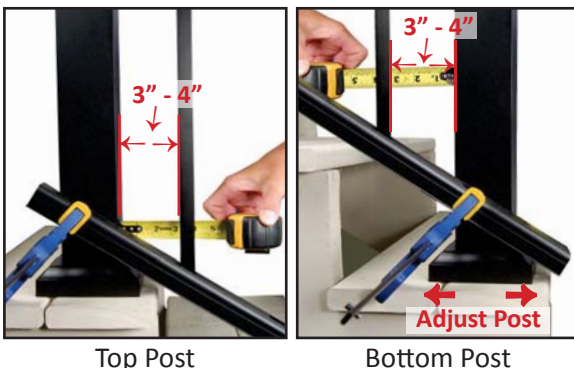

Top Post

Bottom Post

Step 4: Clamp Bottom Rail to Posts

Clamp bottom rail to top and bottom posts, following same angle as stairs. Bottom post is loosely placed at this point. **NOTE:** Ideal installation would have the lower rail rest on the nose of each step, but you may have to install temporary blocks to raise rail slightly to allow clearance of post skirt and bottom rail brackets.



Step 6: Mark Lower Rail Bracket Locations

Hold bracket in place directly behind rail and position bracket to the same angle, position and height of the stair rail. Mark top of bracket on post (a) and also mark where the bracket ends on the rail (b). Do this for both bottom rail brackets. *(White brackets shown for clarity)*

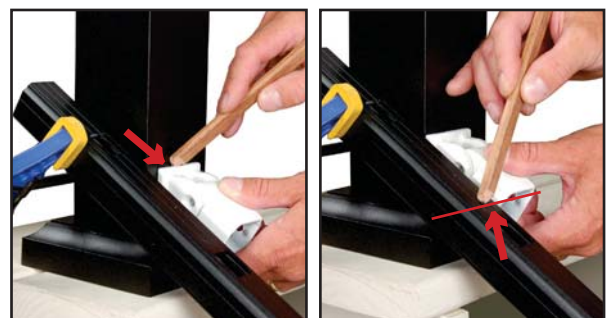

(a) Mark Post

(b) Mark Rail

Stair Rail Installation (Continued)

Step 7: Cut Bottom Rail

Remove clamps and bottom rail from posts. Measure 1" outward from the marks you made on the bottom rail from Step 6b and cut. 1" measurement accounts for bottom rail bracket depth. **Make sure to mark which side is upper and which is lower. All cut ends must be painted to prevent oxidation.**

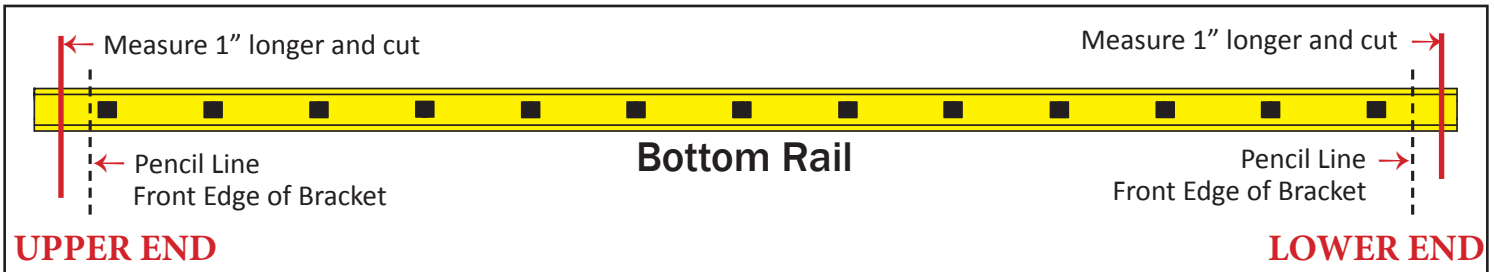

*** IMPORTANT ***

Step 8: Cut Top Rail

Once cut to size, the bottom rail can be used as a template to cut the top rail. Transfer bottom rail length to top rail ensuring that baluster cutouts are in alignment. Mark top rail for reference. From that point, **measure over 1" towards upper end of top rail and cut. Repeat at opposite end of rail. (See diagram below) Make sure to mark which side is upper and which is lower.** (Note: Shifting of the cut line 1" compensates for stair angle to ensure balusters are plumb for standard rail pitches between 32° and 36°) **All cut ends must be painted to prevent oxidation.**

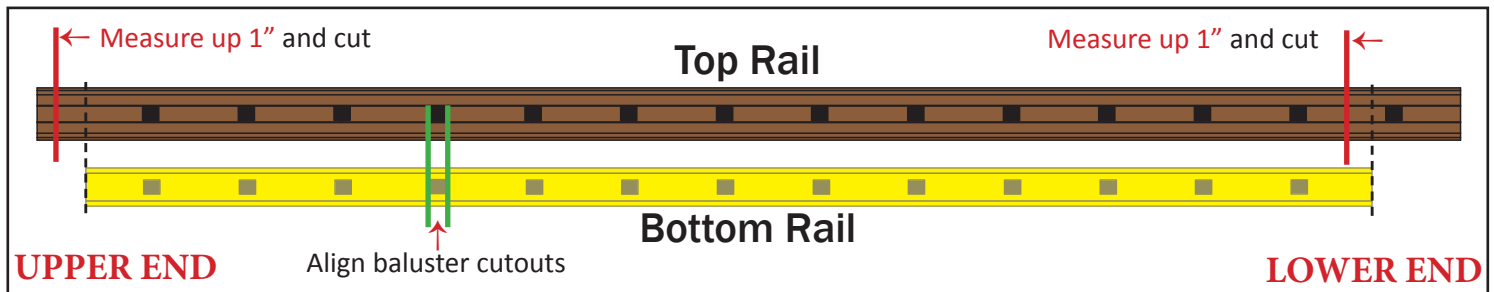

Step 9: Rail Bracket Overview

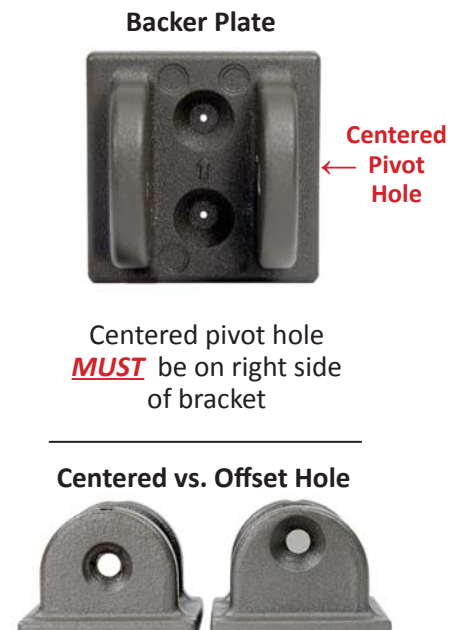
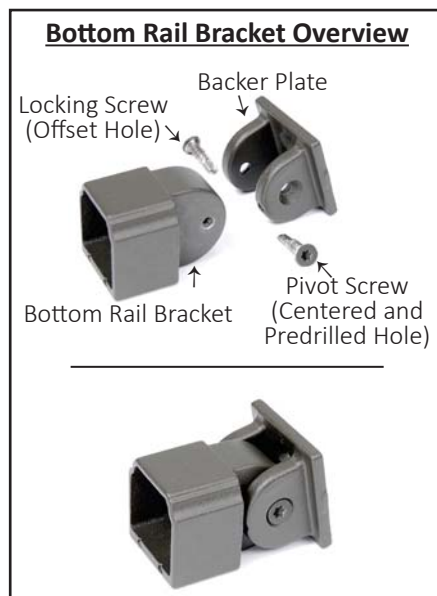
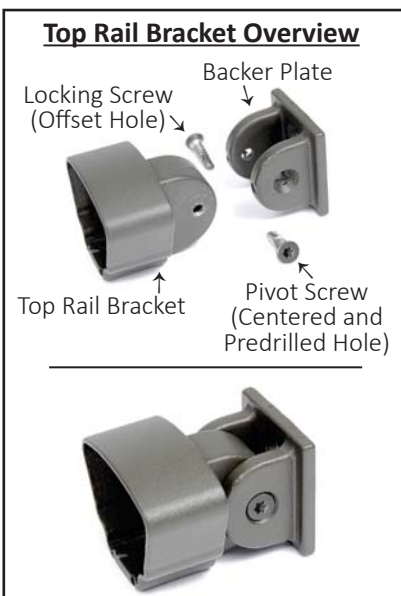

DekPro™ Prestige Aluminum Rail System Stair Railing Installation Instructions

Stair Rail Installation (Continued)

Step 10: Mount Bottom Rail Backer Plate

Separate bottom rail brackets into two pieces by removing the pivot screw, then attach backer plate to the post using mark made from Step 6a. Ensure centered pivot hole is on the right side for both top and bottom posts.



Step 12: Partially Assemble Rail

At this point, bottom rail is in place and secured with pivot screws. Top rail brackets should be placed temporarily onto top rail but not secured. Tape can be used to keep top rail brackets from sliding off. With 3 balusters (top, middle, & bottom), set into lower rail, place top rail into position to partially assemble rail.



Step 14: Mount Top Rail Backer Plate

Separate top rail brackets into two pieces by removing the pivot screw, then attach backer plate to the post using mark made from Step 13a. Ensure centered pivot hole is on the right side for both top and bottom posts.



Step 11: Install Bottom Rail and Bracket

Slide rail brackets onto the bottom rail and use pivot screws to secure rail into place.

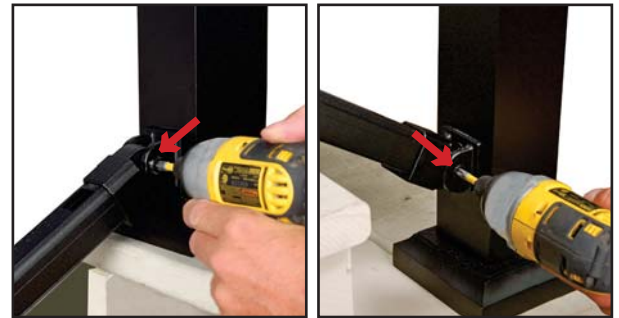

Top Post

Bottom Post

Step 13: Mark Top Rail Bracket Location

Ensure balusters are fully engaged and plumb to accurately locate your top rail brackets. Mark location of top rail bracket both on post (a) and on top rail (b). After marks are made, disassemble the top rail and remove 3 balusters.

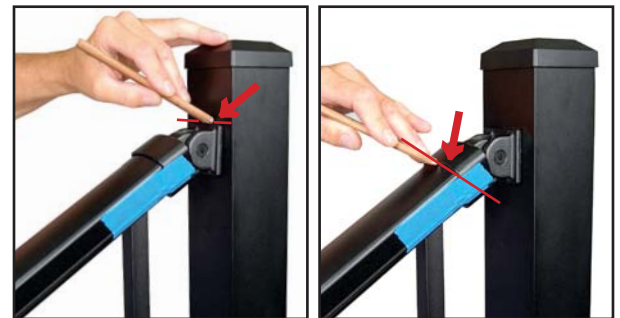

(a) Mark Post

(b) Mark Rail

Step 15: Attach Top Rail Bracket to Rail

Attach rail bracket to top rail. Ensure it lines up with the mark you made in Step 13b.



DekPro™ Prestige Aluminum Rail System Stair Railing Installation Instructions

Stair Rail Installation (Continued)

Step 16: Insert Balusters into Bottom Rail

Insert all balusters into bottom rail with firm downward pressure until they “click” into place. (Slight tap down with rubber mallet may help)



Step 17: Attach Top Rail

First, insert baluster nearest to the lower post (a), then secure bracket into place (b) using the pivot screw. Do not use locking screw yet.



(a) Insert Baluster



(b) Anchor Bracket w/ pivot screw

Step 18: Insert Balusters into Top Rail

Slowly lower upper rail and continue inserting balusters for entire rail. Ensure all balusters are firmly seated in the rails. (Slight tap down with rubber mallet may help)



Step 19: Secure Top Rail into Place

With bracket and backer plate in line, secure rail into place with pivot screw.



Step 20: Finishing Touches

Install all remaining screws to complete rail installation. If additional stair rails are being installed, continue same process.

Install post cap and 2 pc. skirt.

Installed Cap



Installed Skirt





DekPro™ Prestige Textured Aluminum Railing Systems

Multi-Angle Railing



Multi-Angle Rail Installation Guide

- Please read all instructions completely before starting any installation of DekPro™ Prestige Railing Systems.
- **SAFETY:** Always be safe and follow all instructions when using power tools and always wear eye protection!
- Proper blocking must be in place before mounting posts.
- Rail Sections come in nominal 6ft & 8ft lengths. (Actual rail lengths are 70" and 96.75" respectively).
- Residential default finished rail height when using DekPro™ bracket installation Quick Jig is 38" and Commercial is 42".
- Posts are available in RESIDENTIAL rated (3" & 4" posts w/ flange and 4" Sleeve) and COMMERCIAL (3" post w/ flange)
- DekPro™ Prestige Railings should be installed using good building principles in accordance with local building codes and the installation guidelines. Consult your local building code official and check all code requirements before installing railings. DekPro™ or its distributors shall not be held liable for improper or unsafe installations.
- It is the responsibility of the installer to obtain all required building permits and meet code requirements.
- DekPro™ Prestige Railing has been tested by ATI and meets testing standards for IRC and IBC construction codes AC273. Test report CCRR # 0233.
- For questions contact Absolute Distribution Inc., U.S. national distributor for DekPro™ Prestige Railing Systems at 800-335-5909 or www.AbsoluteDist.com

Recommended Tools for Installation

- Level
- Mallet / Hammer
- Speed Square
- Cordless Drill / Impact driver
- Quick clamp grips
- Pencil
- Tape Measure
- Miter saw with high tooth count carbide blade
- 13/64" drill bit (Optional)
- T30 Torx screwdriver bit
- Ratchet Strap

Hardware

Bracket Components

Top Rail Bracket Overview



Bottom Rail Bracket Overview

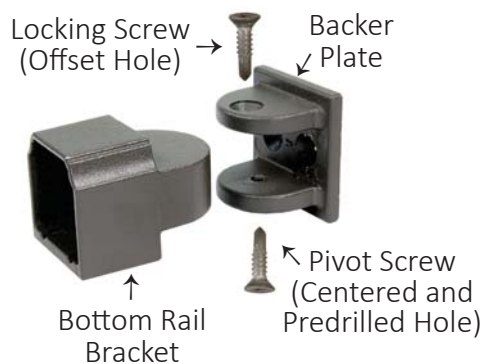

Foot Block



All fasteners for attaching brackets to posts and rails are packaged with kits. #14 T30 Torx, self-drilling screws included. 2 Screws for each backer plate attachment, 2 screws for each bracket attachment and 1 screw for securing rail to bracket. Foot block assembly has 1 self-drilling screw for the foot block and 2 screws for the shoe. All screws are color matched to the rail. Use a T30 Torx screwdriver bit for a sure fit.

Post Placement & Installation

Step 1: Layout

Determine post placement.
If stairs are involved, it may be beneficial to start with post placement at top of stair run.
Ensure proper blocking is in place before mounting posts.

Actual Railing Lengths:

- 70" for 6' rail
- 96-3/4" for 8' rail

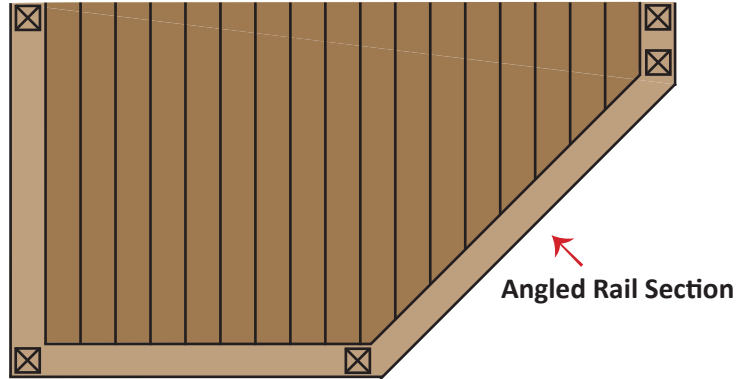

Step 2: Mount Post

- Set post in place and mark four mounting holes.
- Pre-drill holes for mounting hardware, then fasten post with mounting hardware (not included). See below for mounting options.
- Check that post is plumb and shim if necessary (shims included).
**Note: Optional Quick Jig can be used to plumb posts using the attached 2 way level.*
- For 4" sleeve - Slide sleeve over existing wood 4x4 and furr-out as necessary.



Mark and Pre-drill Holes



Fasten Post to Deck Surface



Post Mounting Options

Surface Mount using Carriage Bolt

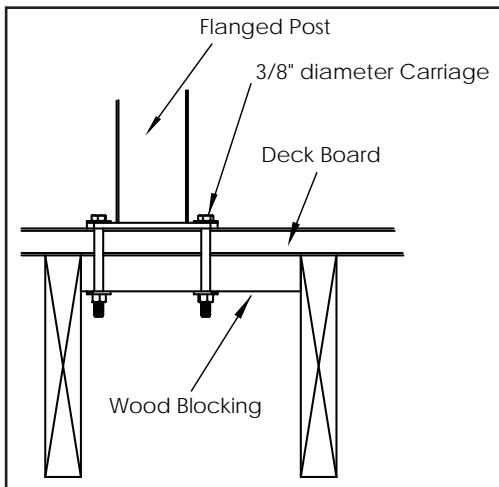

Surface Mount using Lag Bolt

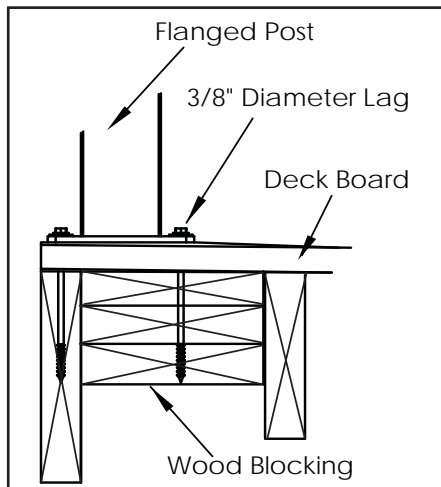

Surface Mount using Concrete Anchor

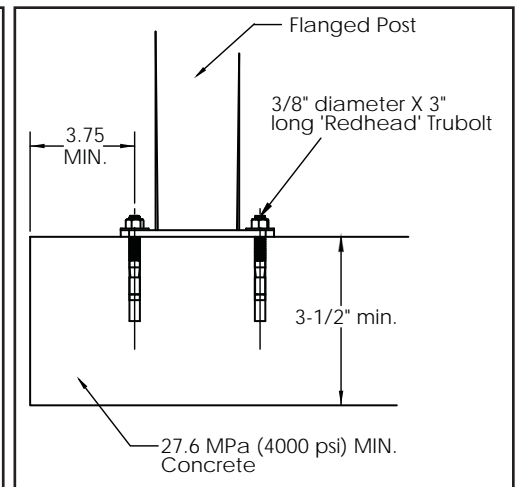

Multi-Angle Bracket Installation

Step 3a: Attaching Brackets to Post

Standard Installation - USING PRESTIGE QUICK JIG

- Clamp Prestige™ Quick Jig to post.
- Mark Bottom Edge of Bracket Cut-Outs.
- Remove Quick Jig.
- Align Bottom of Bracket Backer Plate to the Line Created.
 - Ensure Backer plate is level and centered.
 - Backer plate **MUST** have centered pivot hole on bottom side.
- Use T30 Torx self-drilling screws to fasten backer plate.
 - Mark and Pre-drill holes if desired

*Note: Default finished rail height will be 38" for residential and 42" for commercial.

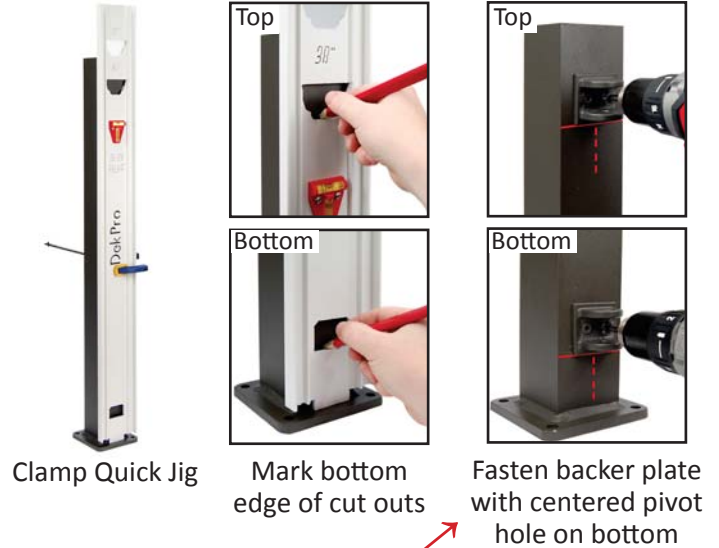

Step 3b: Attaching Brackets to Post

Standard Installation - WITHOUT QUICK JIG

Bottom Rail Bracket Installation:

- Measure up 2-3/8" from the top of the base plate and mark a horizontal line.
- Center the backer plate on the post with the bottom edge of the bracket at the line you marked previously.
 - **MUST** have centered pivot hole on bottom.
- Use T30 Torx self-drilling screws to fasten bracket. (Pre-drill holes if desired)

*Note: Installation for bottom bracket is the same for 38" rail and 42" rail.

Top Rail Bracket Installation:

- **For 38" Rail:** Measure up 35-3/4" from the top of the base plate and mark a line.
- **For 42" Rail:** Measure up 39-3/4" from the top of the base plate and mark a line.
- Center the bracket on the post with the bottom edge of the bracket at the line you marked previously.
 - **MUST** have centered pivot hole on bottom.
- Use T30 Torx self-drilling screws to fasten bracket. (Pre-drill holes if desired)

*Note: Finished rail height will be 38" for residential and 42" for commercial using standard installation procedure with 3-1/8" foot block.

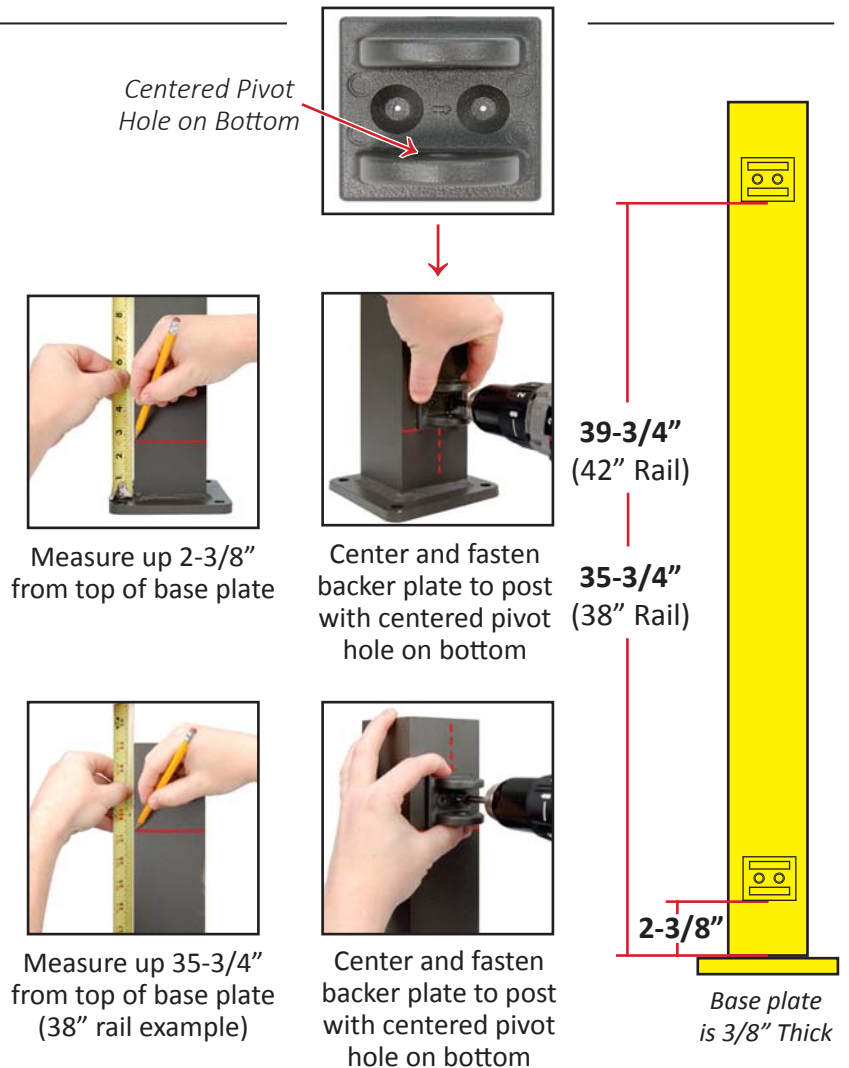

Multi-Angle Rail Installation

Step 4: Attached Bottom Bracket to Backer Plate

Temporarily install the bottom bracket into the backer plate by using a screw into the centered pivot hole.

(A) Start the screw by hand, (B) then use a ratchet or 90 degree screw driver to tighten it. Do this for both sides.



Step 5: Cut Rails to Size

- With bottom brackets temporarily installed, hold the bottom rail next to the brackets to determine where the railing will need to be cut.
- Ensure equal and maximum spacing from end of rail to the first baluster on both ends of the bottom rail. Rails must not exceed 4" spacing between the end baluster and post.
- Using the back edge of the bracket as a reference, mark the railing less 1/8" for bracket wall thickness. (See Image -->)
- Cut bottom rail with a high tooth count carbide blade.
All cut ends must be painted to prevent oxidation.

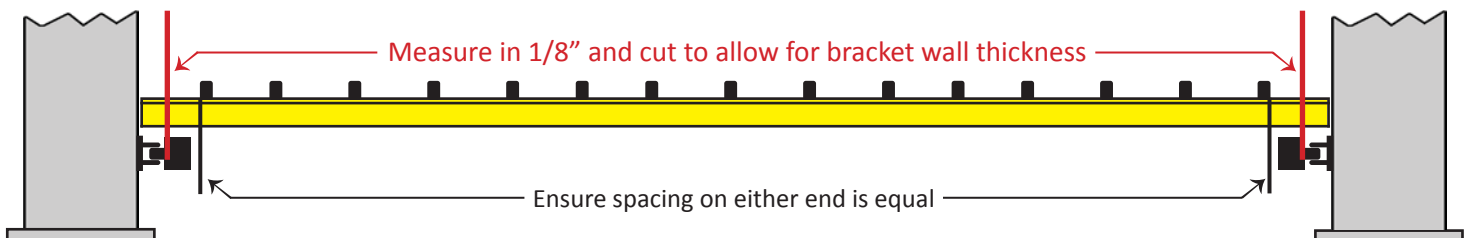

- The bottom rail can then be used to mark and cut the top rail.

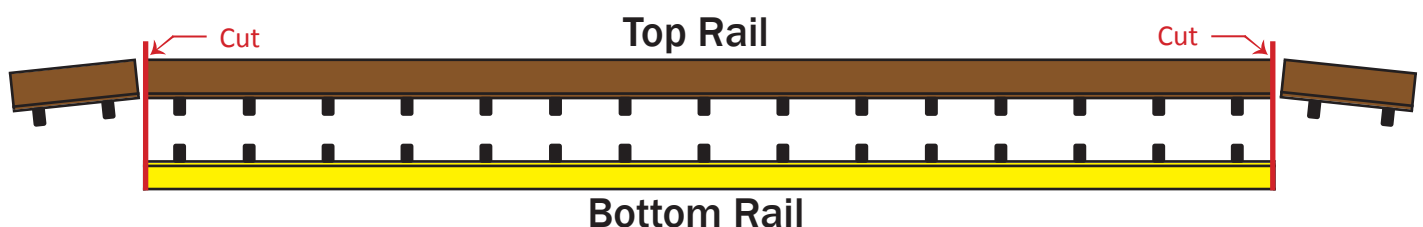

Multi-Angle Rail Installation (Continued)

Step 6: Assemble Rail Kit

A.) Insert balusters onto the baluster connectors of the bottom rail. Insert first two balusters from one end of top rail and progressively work your way to the other end to attach top rail to balusters. **B.)** After all connectors are engaged with the balusters a ratchet strap can be used to pull rails together tightly or use a rubber mallet with a wood board (minimum 12" length) to distribute load evenly and to fully seat balusters into rails.

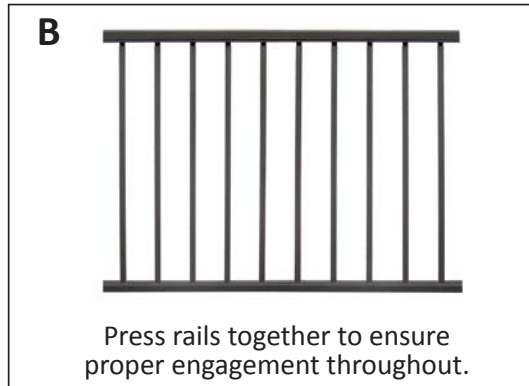
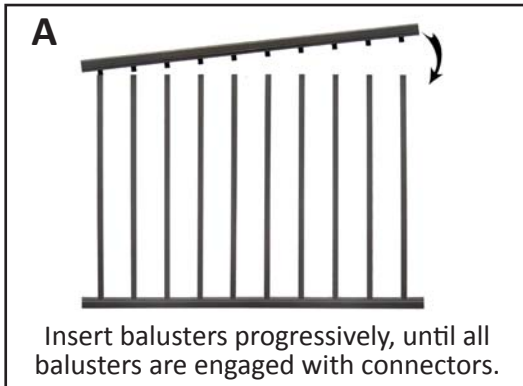

* DekPro™ boxes come with a cardboard rail comb to help align and speed up rail kit assemblies

Step 7: Mounting Foot Block to Rail

- Center and install foot block to bottom rail with 1 ea. self-drilling screw.
- Temporarily attach the foot block shoe to the foot block by pushing it up onto the foot block for a friction fit. *Foot block shoe will attach to the deck surface once railing is set in place.*

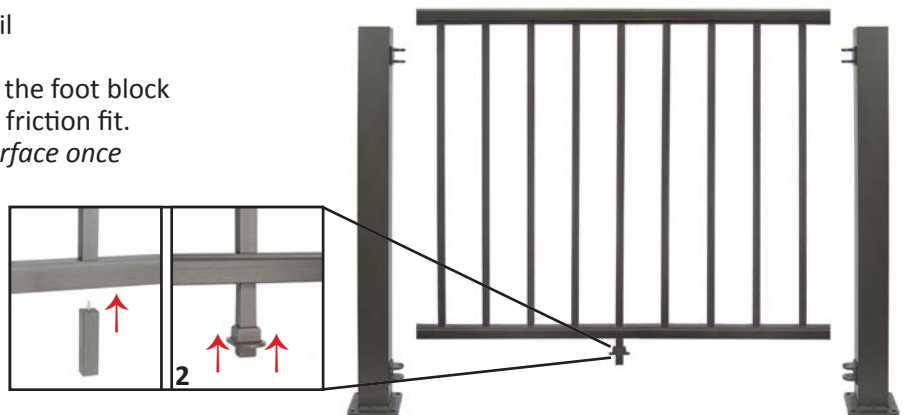

Step 8: Set Assembled Rail into Backer Plates

- Slide railing brackets onto rail. (Do not fasten brackets to rail)
- Set railing with bracket into the backer plates and secure with screws in the existing centered holes on the bottom side of the backer plate. *Use 1 Screw per bracket.*

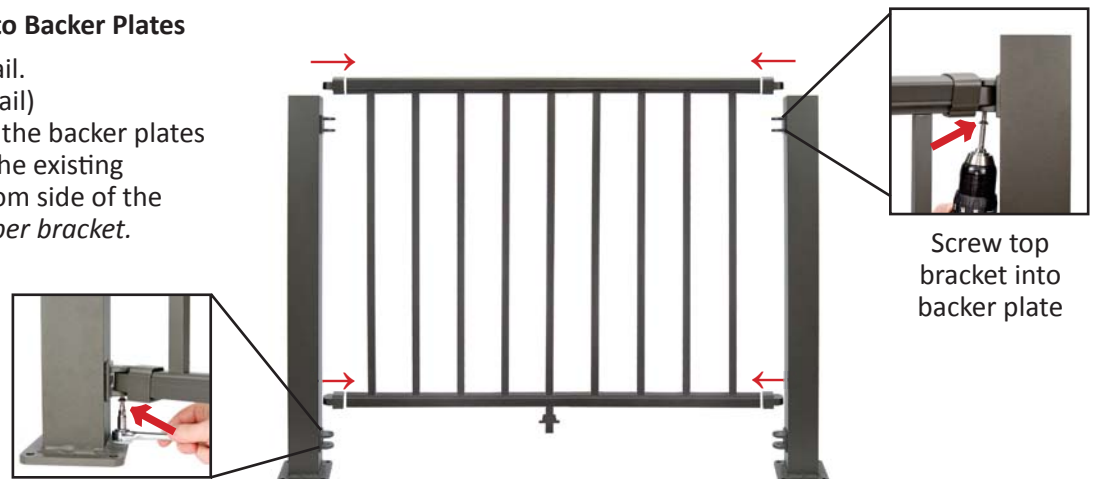

Multi-Angle Rail Installation (Continued)

Step 9: Fasten Rail into Brackets

- Ensure the railing is evenly spaced between posts.
- Fasten brackets to rail.
Use 1 Screw per bracket.



Step 10: Finish Rail Assembly

- Lock brackets into place by installing screw through the upper offset hole of the backer plate into the bracket.
Use 1 Screw per backer plate.
- Attach foot block shoe to deck surface.
Use 2 ea. screws.



Step 11: Final Touches

- Install Post Cap.
Tap down post cap - friction fit.
- Install 2 pc. Post Skirt.
Attaches around base of post.

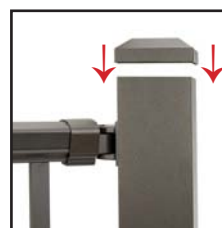

Tap Post Cap Down Evenly



Installed Cap



Start One Side of Post Skirt, Then Snap into place.



Installed Skirt



DekPro™ Prestige Textured Aluminum Railing Systems

Secondary Handrail



Secondary Handrail Installation Guide

- Please read all instructions completely before starting any installation of DekPro™ Prestige Railing Systems.
- **SAFETY:** Always be safe and follow all instructions when using power tools and always wear eye protection!
- DekPro™ Prestige Railings should be installed using good building principles in accordance with local building codes and the installation guidelines. Consult your local building code official and check all code requirements before installing railings. DekPro™ or its distributors shall not be held liable for improper or unsafe installations.
- It is the responsibility of the installer to obtain all required building permits and meet code requirements.
- DekPro™ Prestige Railing has been tested by ATI and meets testing standards for IRC and IBC construction codes AC273. Test report CCRR # 0233.
- For questions contact Absolute Distribution Inc., U.S. national distributor for DekPro™ Prestige Railing Systems at 800-335-5909 or www.AbsoluteDist.com

Recommended Tools for Installation

- Level
- Mallet / Hammer
- Cordless Drill / Impact driver
- Quick clamp grips
- Pencil
- Tape Measure
- Miter saw with high tooth count carbide blade
- 13/64" drill bit (Optional)
- T30 Torx screwdriver bit

Secondary Handrail Component List



1-1/2" x 8' Handrail



Quick Return Bracket



Mid-Rail Bracket



Straight Splice



Multi-Angle Splice



90° Inside/Outside Corner



Inside Corner Bracket



P-Loop Return



Handrail End Cap

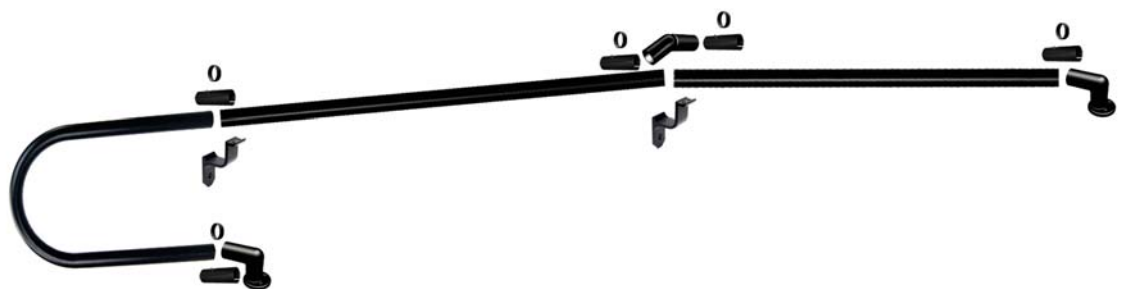

Secondary Handrail Installation Guide

Quick Return Bracket:



Step 1:

Mount quick return bracket to post at desired angle with 2 ea. Torx screws.

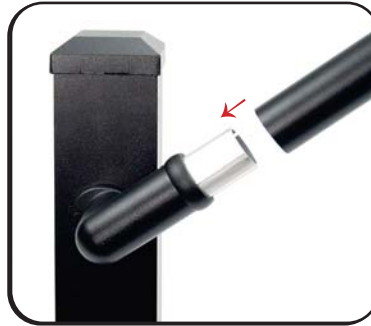

Step 2:

Slide rail onto splice to connect rail and quick return bracket. (Bracket includes splice and splice ring)



Step 3:

Secure rails together using epoxy adhesive (Not Included).

Mid-Rail Bracket:



Step 1:

Mount mid-rail bracket to post with 1 ea. Torx screw.



Step 2:

Set rail into place.



Step 3:

Fasten rails onto mid-rail bracket using 2 ea. Torx screws.

Mid-Rail Bracket Angled:



Step 1:

Mount mid-rail bracket to post at desired angle with 1 ea. Torx screw.



Step 2:

Set rail into place.



Step 3:

Fasten rails onto mid-rail bracket using 2 ea. Torx screws.

Secondary Handrail Installation Guide

Straight Splice

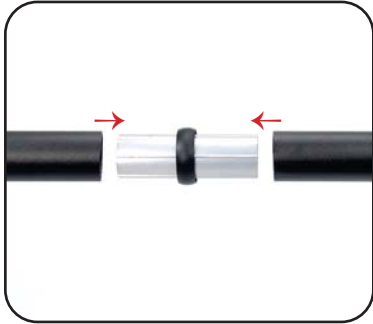

Step 1:

Slide rail onto splice from both ends.



Step 2:

Fasten splice into rails using screws or adhesive (Not Included).

Straight Splice at Mid Rail Bracket:

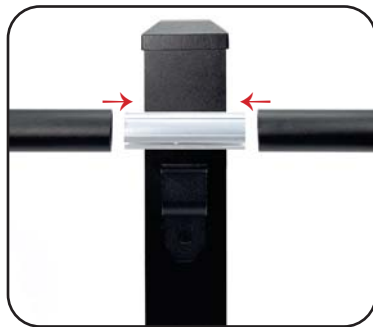

Step 1:

Slide rail onto splice from both ends. (Splice ring NOT used in this scenario)

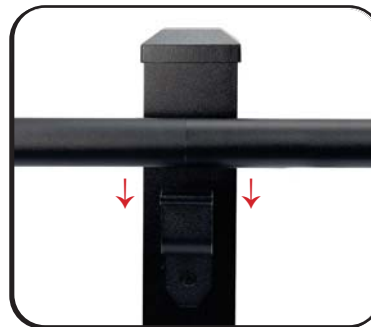

Step 2:

Set rail onto mid-rail bracket.



Step 3:

Fasten rails onto mid-rail bracket using 2 ea. Torx screws.

Universal Angle Splice:

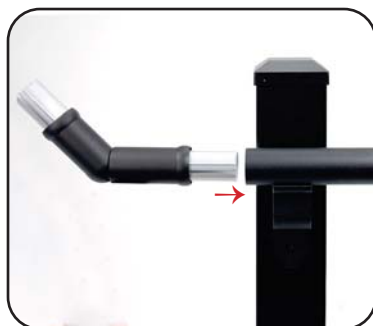

Step 1:

Slide universal angle splice into rail.

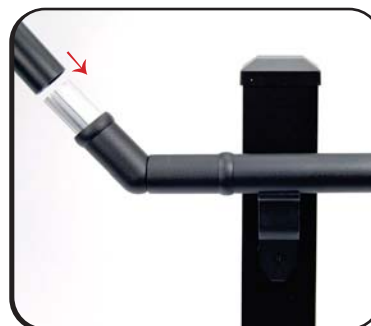

Step 2:

Slide rail onto universal angle splice.



Step 3:

Secure rails together using epoxy adhesive (Not Included).

Secondary Handrail Installation Guide

P-Loop Return

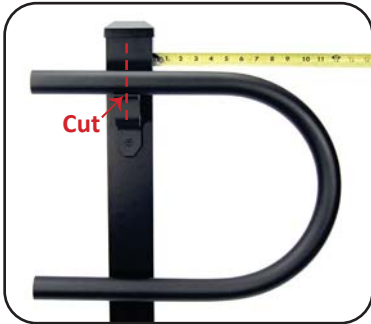

Step 1:

Locate and attach mid-rail bracket. Ensure that the P-loop extends a minimum of 12" beyond the step then cut P-Loop at half way point of mid-rail bracket.



Step 2:

Attach universal angle splice or straight splice depending on application.



Step 3:

Fasten splice and P-loop onto mid-rail bracket using 2 ea. Torx screws.

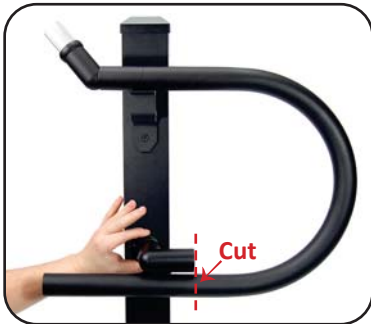

Step 4:

Center the quick return bracket on post and align it with bottom end of the P-Loop. Mark and cut at P-loop where bracket ends.



Step 5:

Connect quick return bracket to rail using splice included with bracket. Secure rails together using epoxy adhesive (Not Included)



Step 6:

Fasten quick return bracket to post using 2 ea. Torx screws.

End Cap Attachment



Step 1:

Slide end cap into open end of rail.



Step 2:

Secure end cap into rail using epoxy adhesive (Not Included).

Secondary Handrail Installation Guide

Inside Corner Bracket:



Step 1:

Mount inside corner bracket to post with 4 ea. Torx screws.



Step 2:

Place 90 degree inside corner rail onto bracket. Ensure rail is even and level.



Step 3:

Fasten rail onto bracket using 2 ea. Torx screws.

Outside Corner Rail:



Step 1:

Mount mid-rail brackets to post with 1 ea. Torx screw per bracket



Step 2:

Set outside corner rail onto mid-rail brackets. Ensure rail is even and level



Step 3:

Fasten rails onto mid-rail brackets using 2 ea. Torx screws per bracket.

DekPro™ Prestige

Textured Aluminum Railing Systems

Gate Assembly



DekPro™ Prestige Aluminum Rail System Gate Kit Assembly Instructions

Gate Kit Assembly

Materials Needed:

- 1 - Gate Upright Kit (Comes with 2 posts, 4 caps, & fixed top rail connection)
- 1 - Rail Section (6' rail kit or cut rail)
- 2 - Bottom Rail Brackets (If using cut rail)
- 1 - Gate Hinge Set (Includes 2 Hinges)
- 1 - Latch Kit

(All hardware is included to gate kit assembly)



Step 1: Cut Gate Uprights to Length

Gate uprights are designed to accommodate for both a 36" rail height gate or 42" rail height gate.

For 36" Gate:

- Measure down from bottom side of top rail bracket 34" and cut.

For 42" Gate:

- Measure down from bottom side of top rail bracket 38" and cut.

**Repeat step 1 for both gate uprights*

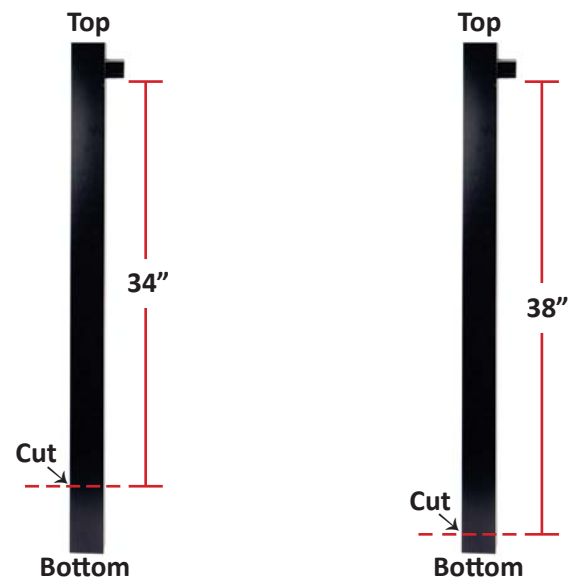

Step 2: Attach Bottom Rail Brackets

- Measure up 3/4" from the bottom of gate upright and center the bracket
- Fasten bracket to gate upright using self-drilling screws (Pre-drill holes if desired)

**Repeat for both gate uprights*

**3/4" space allows for gate swing clearance and for caps to be attached.*

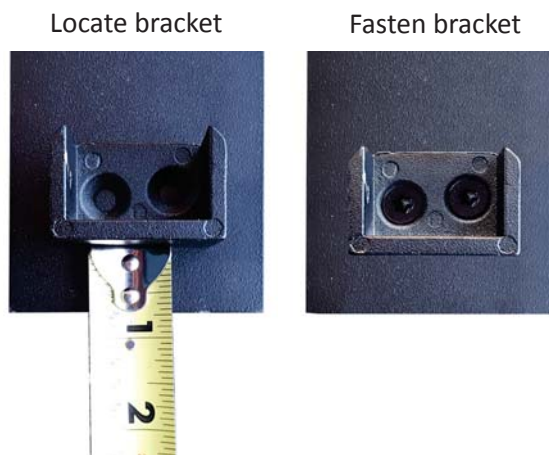

DekPro™ Prestige Aluminum Rail System Gate Kit Assembly Instructions

Gate Kit Assembly

Step 3: Determine Bottom Rail Length and Cut

- Measure distance between existing posts
- Subtract 7-1/2" from that distance
 - 1/2" for gate hardware on either side (1" total)
 - 3" for each gate post (6" total)
 - 1/4" for each bracket wall (1/2" total)
- The result will be the final length that the bottom rail needs to be cut.

**Example:*

*Distance between existing post is 39-1/2"
Less 7-1/2" for gate posts and hardware
Equals 32" that the bottom rail needs to be cut to*

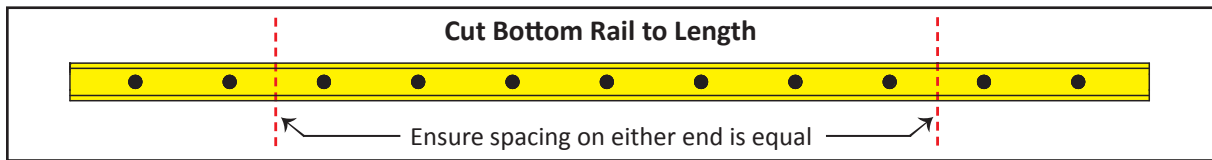

*** IMPORTANT ***

Step 4: Cut Top Rail

Once cut to size, the bottom rail can be used as a template to cut the top rail. Transfer bottom rail length to top rail ensuring that baluster connectors are in alignment. **Mark top rail for reference. From that point, measure out 3" towards end of top rail and cut. Repeat at opposite end of rail.** (See diagram below). Baluster connectors may have to be removed from top rail to allow the top rail to slide into the gate post. May require drilling out pop rivets. **All cut ends must be painted to prevent oxidation.**

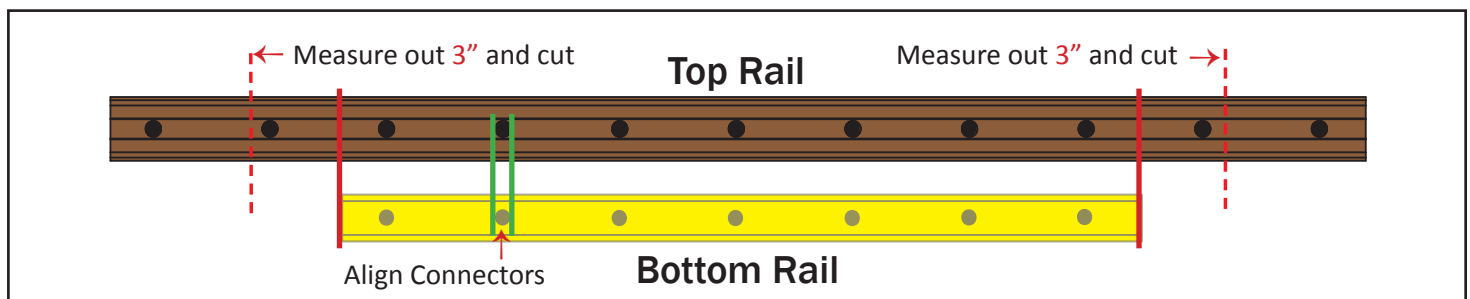

Step 5: Assemble Gate Rail

- Insert balusters onto the baluster connectors of the bottom rail.
- Insert first two balusters from one end of top rail and progressively work your way to the other end to attach top rail. After all connectors are engaged with the balusters a ratchet strap can be used to pull rails together tightly or use a mallet / hammer and wood board (minimum 12" length) to distribute load evenly and to fully seat balusters.

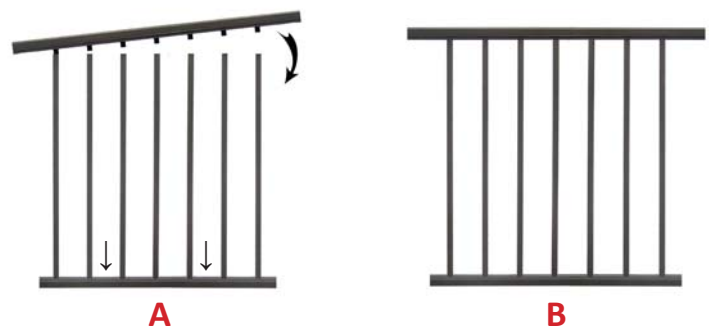

DekPro™ Prestige Aluminum Rail System Gate Kit Assembly Instructions

Gate Kit Assembly

Step 6: Mount Assembled Rail into Brackets

Sandwich the railing between the gate uprights. Slide rail into brackets and secure with screws. Set top bracket screw first to pull rail down tightly into bottom brackets. Then screw bottom bracket to secure rails in place.

**Note: Set screw gun on "Screw" mode not "Drill" mode.*



Top rail slides into bracket and gate upright.

Step 7: Finish the Gate Rail

A.) Install bottom rail bracket covers using a mallet/hammer and wood block to seat the bracket covers properly onto the bracket.

IMPORTANT! - Bracket cover must be tapped straight down. Bracket cover tabs may break if driven down at an angle.

B.) Then install post caps. (Caps are friction fit or can be secured with silicone adhesive)

Note: Drill a small hole into the bottom cap before installing to create a weep hole. Use Touch-up paint to finish the hole.

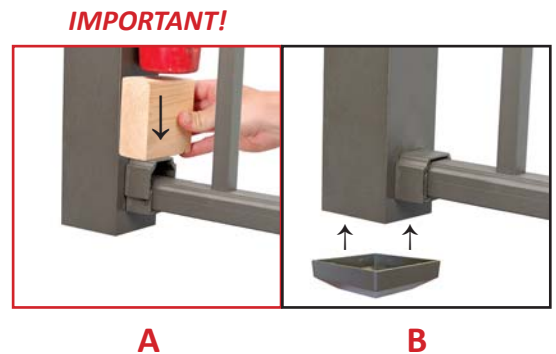
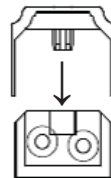

IMPORTANT!

A

B

Step 8: Install Hinges and Latch

- Locate desired location for hinges, then mount (creates a 1/2" space between post and rail)
- Locate desired location for Latch, then mount (creates a 1/2" space between post and rail)

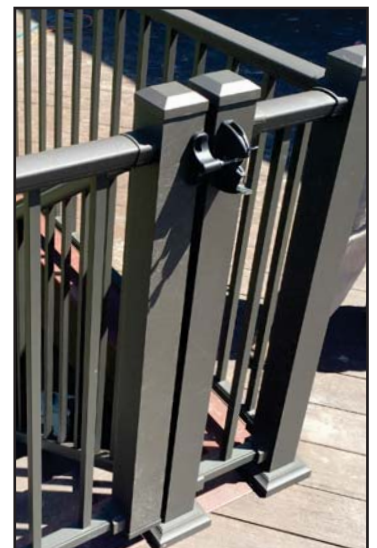
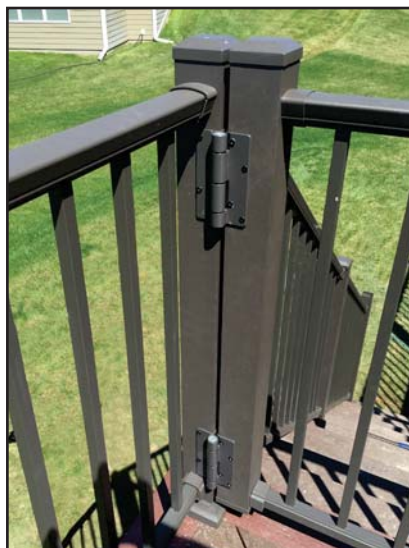

DekPro™ Prestige Aluminum Rail System Gate Kit Assembly Instructions

Gate Kit Assembly with Cable Anti-Sag Kit

Step 1: Follow Gate Installation Instructions

Follow gate installation instructions thru Step #5 to get you to this point in the installation where the uprights and rails are cut to the proper lengths.

** Denote which gate upright will have the hinges and which will have the latch. In this example "Upright A" will have the hinges and "Upright B" will have the latch.*



Cable Anti-Sag Kit Includes:

- 1 - 5' Stainless Steel Cable
- 1 - Tensioning Receiver Fitting
- 1 - Pull-lock Fitting w/ End Cap
- 2 - Washers

Step 2: Locate and Drill Holes for Cable Fittings

Upright A: Measure down from top bracket 1" and in from the edge of the upright 3/4"

Upright B: Measure up from bottom bracket 1" and in from the edge of the upright 3/4"

Ensure that the holes are drilled in the proper orientation. Either on the front or back side of gate.

** Tools required: 29/64" drill bit, PI-key, & 3/16" hex wrench*



Step3: Install Cable Anti-Sag Kit

Assemble the gate and install cable. Turn the cable into the receiver 2-3 threads to engage it into the fitting. Pass the open end of cable through the pull-lock fitting and pull the cable tight. Cut excess cable from pull-lock fitting.

** Tensioning receiver should be used on "Upright A" which is the upright with the hinges.*

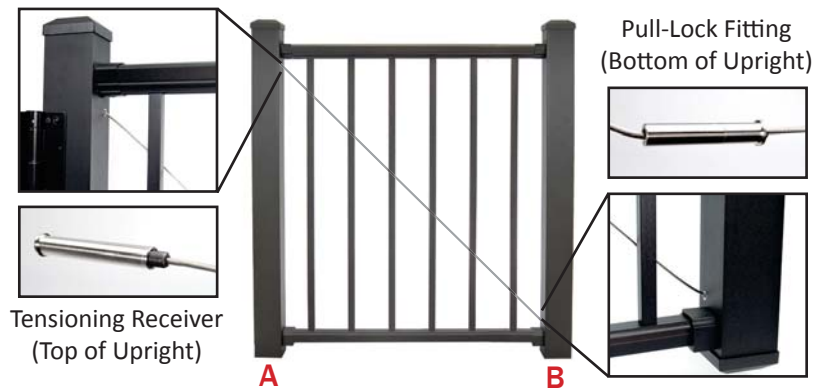

Step4: Install Gate and Tension Cable

Install the gate between posts. Tension the cable until the gate sits level between the railings. The cable can be tensioned as needed throughout the life of the gate.





DekPro™ Prestige Textured Aluminum Railing Systems

**Tri-Rail Design
& Drink Rail Bracket**



DekPro™ Prestige Aluminum Rail System Tri-Rail Installation Instructions

Tri-Rail Installation Instructions

Materials Needed:

- 2 - Bottom Rail Brackets
- 1 - Mid-Rail (96-1/4")

Step 1:

Ensure that Steps 1 - 4 have been done from the level railing instructions on pages 3 - 5 of this booklet to get you to this point of the installation.



Step 2:

Once cut to size, the bottom rail can be used as a template to cut the mid rail. Transfer bottom rail length to mid rail ensuring that baluster cutouts are in alignment. Mark Mid-Rail for reference, then cut. Repeat at opposite end of rail. (See diagram below) **All cut ends must be painted to prevent oxidation.**

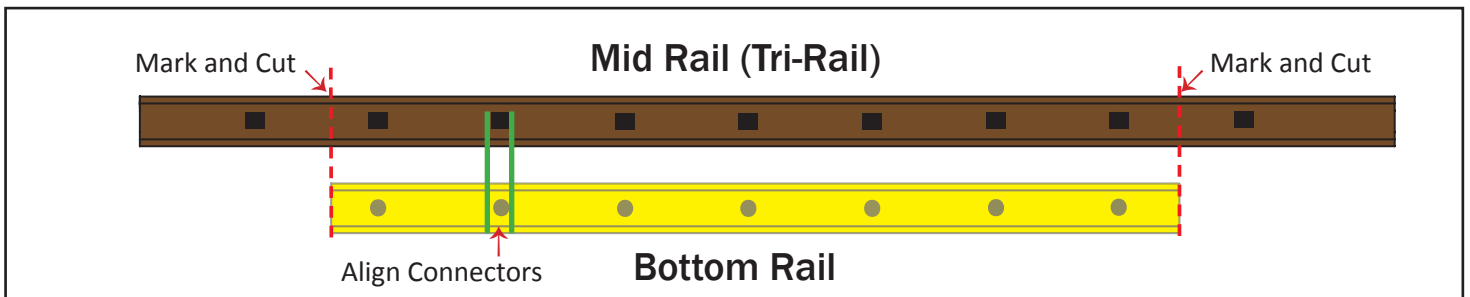

Step 3:

Place balusters into bottom rail and set bottom rail into bottom rail brackets. Then slide Mid-Rail down the balusters. (Mid-Rail stays loose at this point)



Step 4:

Set the top rail onto balusters. Then, determine distance of Mid-Rail to Top Rail.

Note: Mid-rail includes optional screws to secure mid-rail to each baluster.



DekPro™ Prestige Aluminum Rail System Tri-Rail Installation Instructions

Tri-Rail Installation Instructions

Step 5:

Locate brackets. With the Mid-Rail temporarily held in place, slide the bracket on the Mid-Rail to determine the location of the bracket. Mark location on both posts.



Step 7:

With all brackets installed, place the assembled railing into the brackets.



Step 6:

Remove rail section and then center the bracket on the post with the bottom edge of the bracket at the line you marked previously. Use T30 Torx self-drilling screws to fasten bracket. (Pre-drill holes if desired)



Step 8a:

Secure rails into brackets with screws. Install top bracket screw first to pull rail down tightly. Then screw mid bracket and bottom bracket to secure rails in place.



Step 8b:

Use a mallet/hammer and wood block to seat bracket cover onto bracket. **IMPORTANT: Bracket cover must be tapped straight down or tabs may be damaged.**

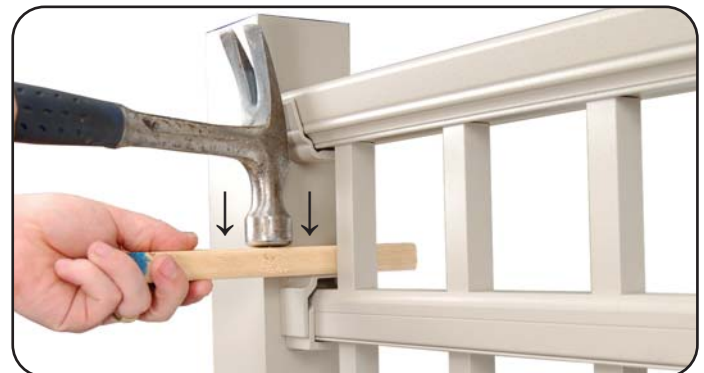

Drink Rail Bracket Installation Instructions

Materials Needed:

Drink Rail Brackets

3 per 6' rail section
4 per 8' rail section



Step 1:

Attach drink rail brackets to top rail using #14 self-drilled screw (Included). Drink rail brackets should be spaced around 2' - 3' apart. (3 brackets for 6' rails / 4 brackets for 8' rails).



Step 2:

Cut Cap rail to length to be placed on top of the railing.

Note: It is recommended not to use the top rail bracket covers.

(Option to use bracket covers would require removing some material from the cap rail.)

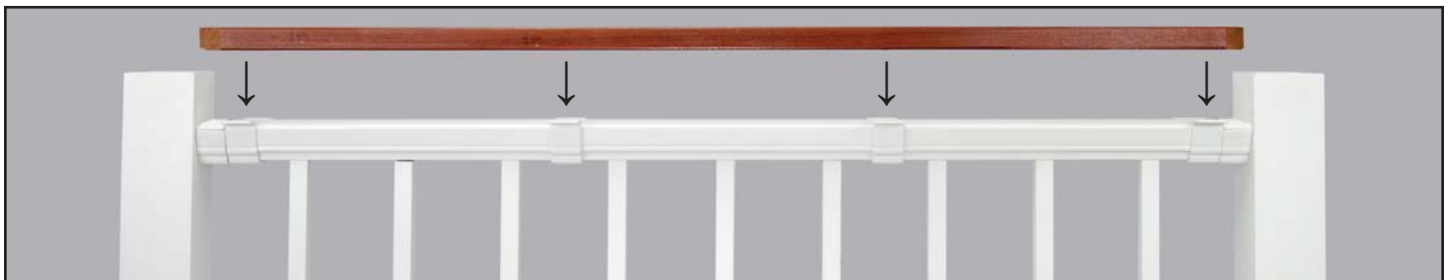

Step 3:

Fasten cap rail to top rail using the drink rail brackets and the included screws.
2 screws per bracket, one on each side of the rail.



DekPro™ Prestige Textured Aluminum Railing Systems

Cable and Glass Rail



DekPro™ Prestige Aluminum Rail System Cable Railing Overview

Cable Railing Overview

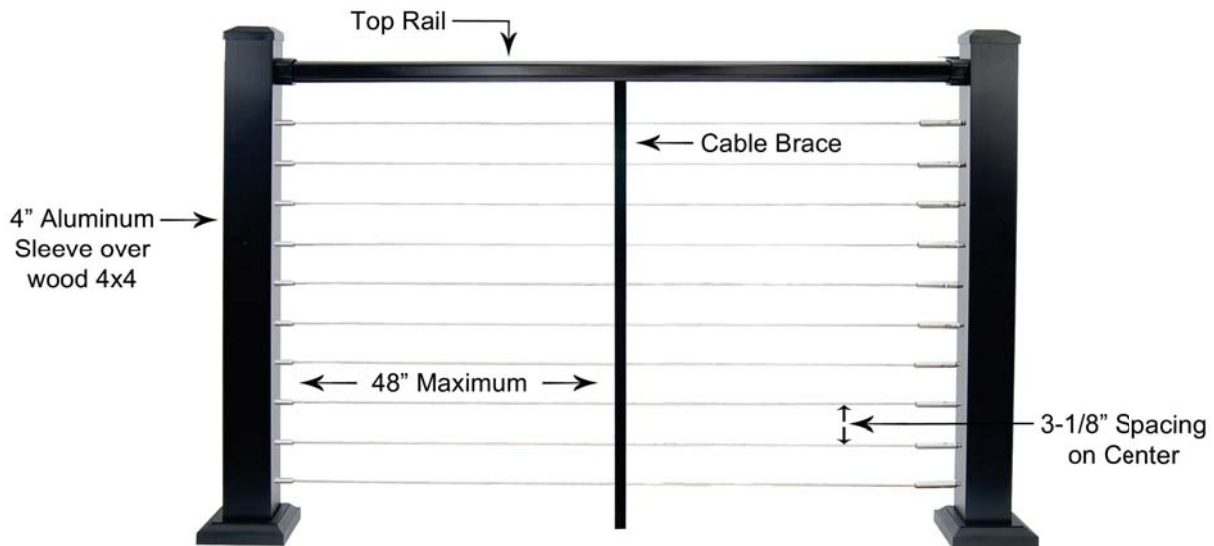

Materials Needed:

4" Post Sleeve
4" Post Cap
4" Post Skirt
Top Rail (6' or 8')
Top Rail Bracket

FlexFX Cable Fittings for Level
FlexFX Cable Fittings for Stair
Cable Brace
9/32" Drill Bit
5/32" Drill Bit

2 - 7/16" open end wrench
Cable Cutting Tool
FlexFX Install Kit:
Includes drill bits, wrenches, lag driver, and release keys

Installation Overview

- Use 4" aluminum sleeve over a 4x4 wood post for structural support.
- Sleeves need to be drilled to allow cable fitting to pass through the sleeve and anchor into wood post.
- Top rail is required. (Bottom rail is optional)
- Cables are to be spaced at 3-1/8" on center.
- Cable must be supported every 48" to keep the cable from deflecting over 4" (Use cable brace)
- 36" Rail height typically uses 10 runs of cable, 42" rail height typically uses 12 runs of cable.
- Lag style cable fittings are required for cable used with sleeved posts.
- Cable kits must terminate at corner posts, or any posts where the cable exits at an angle.

Level Runs use:

RFXWLT - Tensioner Fitting
RFXWLN - Non-Tensioner Fitting
and Bulk Cable (100' or 500')

Stair Runs use:

RFXWST - Stair Tensioner Fitting
RFXWSN - Stair Non-Tensioner Fitting
and Bulk Cable (100' or 500')



Glass Railing Overview

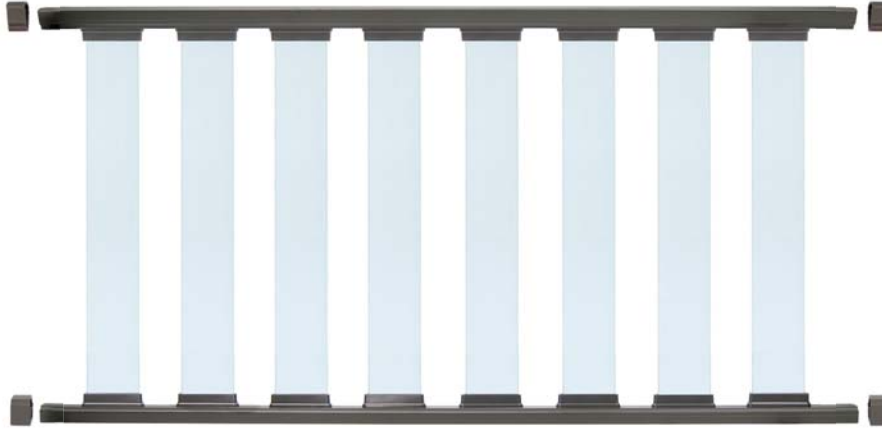

Materials Needed:

Top Rail (6' or 8')
Bottom Rail (6' or 8')
Bracket Cut Kit

32" Glass Balusters (9 for 6' • 12 for 8')
Glass Baluster Connectors
#8 x 1" - Self-Drilling Screws

Installation Overview

DO NOT USE QUICK JIG FOR BRACKET PLACEMENT FOR GLASS RAILS

- Use 3" post or 4" aluminum sleeve to support rails.
- Top and Bottom rails Do Not come with glass baluster connectors pre-attached.
- Glass baluster connectors need to be attached to top rail bottom rails. It may be beneficial to layout the connectors on the rail before attaching to ensure even and equal spacing.
- Baluster connector edges should be spaced 3" apart or less so that glass baluster spacing does not exceed 4" per code requirements.
- Connectors do not include screws for metal rail. Self-drilling #8 x 1" screws must be purchased separately.
- Typical 6' rails will use 9 glass balusters and 8' rails will use 12 glass balusters.
- Once glass baluster connectors are attached to railings, installation is similar to standard rail install.
(Please Note: - **DO NOT USE QUICK JIG FOR GLASS RAIL BRACKET PLACEMENT.**)
- Ensure there is even and equal spacing between the glass balusters and post on either end.





WWW.DEKPROMFG.COM

Marketed and Distributed by:

